

POWER TECHNOLOGY LINE PT "N" SERIES

PNEUMATIC ACTUATORS



AIR TORQUE[®]

DESIGN AND INNOVATION

The technical features incorporated in the **PT "N" Series** pneumatic actuators, permits to have many benefit and versatility for an easier valve automation.

RANGE AND OPTIONS

The **PT "N" Series** pneumatic actuators are available in:

- Seventeen models
- Spring return and double acting versions
- Torque up to 10.000 Nm / 88.500 Lb-In
- As minimum 5 different protection levels
- Low and high temperature constructions
- Large availability of many ISO flanges and drive shaft connections for direct valve automation

Available options upon request:

- 120°-135°-180° rotation both in double acting and spring return
- 180° spring return Fail-Mid
- 3 Position actuators, 90° and 180° rotation, both double acting and spring return versions
- Fast acting actuators
- Hydraulic damper actuators
- Lock-Out capability in fully open or fully close position
- 100% travel stop adjustment.
- Stainless steel



PRODUCT QUALITY, TECHNOLOGY AND MATERIAL

The **PT "N" Series** pneumatic actuators, have been designed and tested to obtain the highest cycling life and the most reliable performance with low maintenance and service.

Our actuators are manufactured with the highest quality material through hard selected vendors to ensure all safety and specs requirements are met or exceeded.

INTERNATIONAL STANDARD

The **PT "N" Series** pneumatic actuators is designed, manufactured and tested in full compliance with all the applicable International standards.



Since many years recognized as a partner of excellence in several fields such as:



chemical



petrochemical



pharmaceutical



power generation

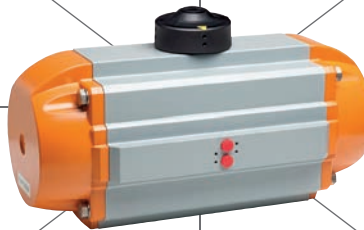

pulp and paper



water treatment



food and beverage



oil and gas

1. Alodur hard anodized body

Extruded aluminum body with Alodur special hard anodization applied internally and externally for a complete corrosion protection, a lower friction coefficient and an increased surface hardness for the longest wearing resistance. Additional protective coatings are available on the external surface for different environmental working conditions.

2. Piston design

Dual piston rack and pinion design for compact construction, symmetric mounting position, high-cycle life and fast operation. Reverse rotation can be accomplished in the field by simply inverting the pistons. Both pistons are anodized for a better corrosion and wearing resistance.

3. Two independent external travel stop adjustments

As a standard, travel stops allowing adjustment for -5° up to $+5^\circ$ on the close position, and for $+5^\circ$ up to -5° on the open position. This allows accurate valve alignment.

4. Universal and anti-blowout drive shaft

Blow-out proof, integral drive-shaft is available with double square as standard. This allows for reduced inventory. Others connections are available on request.

5. One compact and unique design

Double acting and spring return actuator have identical body and end caps to help reduce inventory. This design also supports easy field conversion by adding or removing spring cartridges

6. Position indication

Our actuators come with visual indicator as standard. Other types of position indicators suitable for direct mounting of sensors (P+F, IFM, etc.) and mechanical limit-switches available on request.

7. Multiple bearings and guide

Bearings on piston and racks for precise operation, low friction, high cycle life and piston guides preventing shaft blow-out.

8. Modular preloaded spring

Cartridge design in high grade coated steel for simple range versatility, greater safety and corrosion resistance.

9. Hardened surface on drive-shaft

Surface hardened and protected against corrosion with nickel plating or hard anodizing, Blow-out proof, bearing guided for improved safety and maximum cycle life.

10. Fully machined teeth

On piston racks and pinion shaft for accurate positioning, low backlash and maximum engagement resulting in overall efficient operation.

11. Selected and high quality bearings and seals

Provide a wide operating temperature range, low friction and high cycle life.

12. Fasteners

Stainless steel fasteners for long term corrosion resistance

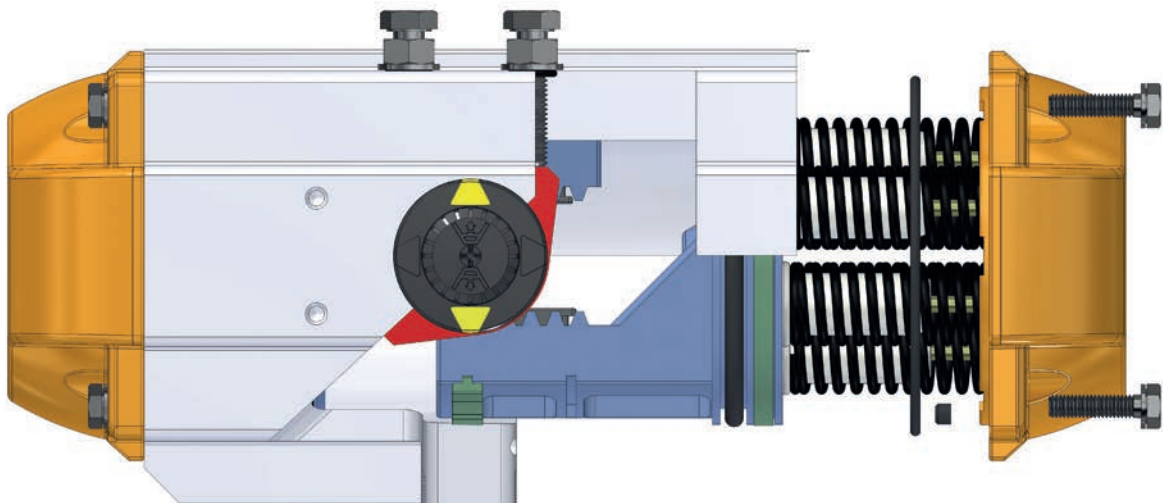



13. Full compliance

To specifications ISO 5211, DIN 3337 and VDI/VDE 3845 providing the product interchangeability and the easiest valve automation and accessories installation.

14. Actuator Marking Traceability

Each actuator is marked with detailed information regarding product description, connections and working conditions; furthermore each individual actuator is produced with a serial number for full traceability. For actuator marking see How to Order

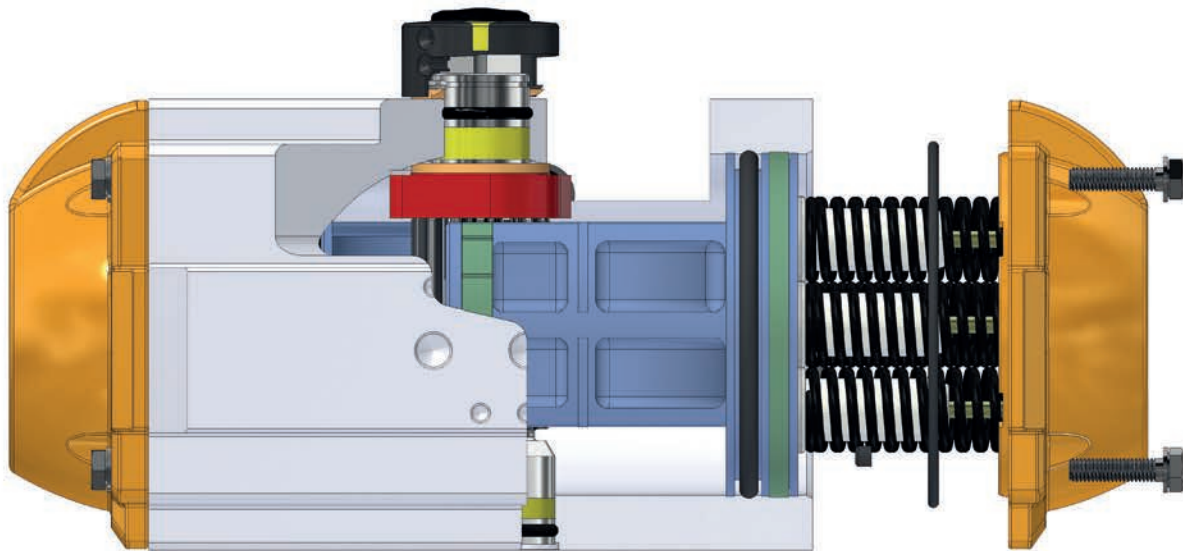

CERTIFICATION



Products approvals/compliance/certificates

- ATEX 2014/34/EU
- DNV Type Approval
- SIL3

- EU Declaration of conformity
- TR CU 010/2011
- TR CU 012/2011
- IP67 and IP68 - Degree of protection

ACTUATOR OPERATING CONDITIONS

1. Operating media

Dry or lubricated air, inert/non-corrosive gases provided that they are compatible with the internal actuator parts and lubricant. See the technical data-sheet for details. In some cases a liquid media can be used to operate the actuator so long as the media is compatible with internal parts and lubricant. Cycles times may also be slower depending on the viscosity of the liquid media. Its recommended that Air Torque's technical department review any applications where liquid media is needed.

2. Supply pressure

For Double Acting and Spring Return actuators the maximum supply pressure is up to 8 bar (116 PSI), the minimum supply pressure is 2.5 bar (36 PSI). Design pressure 12 bar (170 PSI).

3. Working Temperature

- **Standard** actuator construction suitable from -40°C (-40°F) to $+80^{\circ}\text{C}$ ($+176^{\circ}\text{F}$)
- High temperature - **HT** - actuator construction suitable from -15°C ($+5^{\circ}\text{F}$) to $+150^{\circ}\text{C}$ ($+302^{\circ}\text{F}$)
- Extreme low temperature - **LLT2** - actuator construction suitable from -60°C (-76°F) to $+80^{\circ}\text{C}$ ($+176^{\circ}\text{F}$)

4. Lubrication

Actuators are factory lubricated for life under normal operating conditions. The standard lubricant is suitable for use from -40°C (-40°F) to $+80^{\circ}\text{C}$ ($+176^{\circ}\text{F}$).

5. Installation

Actuator suitable both for indoor and outdoor installation. IP rated up to IP68

6. Protection and Corrosion resistance

PT "N" Series pneumatic actuators are available in 5 different protection levels suitable for different environmental conditions. All bolting in stainless steel. For severe duties select from the protection level table or contact AIR TORQUE.

7. Actuator designation and Marking

To have a correct actuator selection, the operating conditions have to be evaluated and defined; they will be marked on the actuator identification label.

ACTUATOR FUNCTION AND ROTATION

The standard actuator rotation is clockwise to close, a counter-clockwise rotation is achieved when port 2 is pressurized. Non standard actuator rotation is counter-clockwise to close, a clockwise rotation is achieved when port 2 is pressurized. See the technical data-sheet for details.

Double Acting operation function (standard rotation) TOP View:

Air supplied to Port 2 forces the pistons towards the actuator end caps, with the exhaust air exiting from Port 4, a counter-clockwise rotation is achieved.

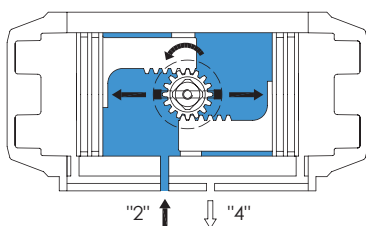

Air supplied to Port 4 forces the pistons inward, exhaust air exits from Port 2, a clockwise rotation is achieved.

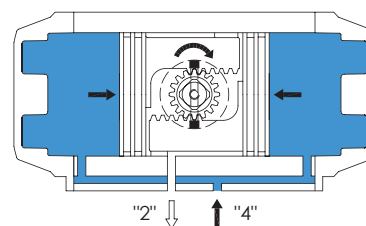

Single Acting operation function (standard rotation) TOP View:

Air supplied to Port 2 forces the pistons toward the actuator end caps, compressing the springs, with the exhaust air exiting from Port 4, a counter clockwise rotation is achieved.

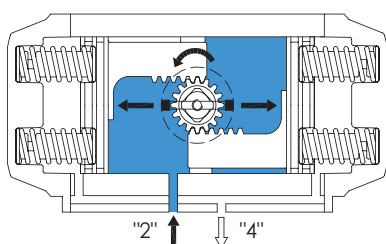

The loss of air pressure (air or electric failure) at Port 2 allows the springs to force the pistons inward with the exhaust air exiting from Port 2, a clockwise rotation is achieved.

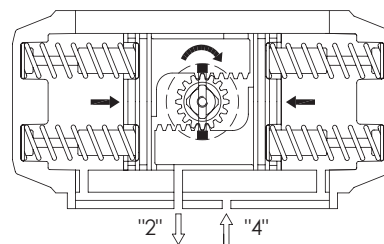

SPRING SET CONFIGURATION

PT045 configuration

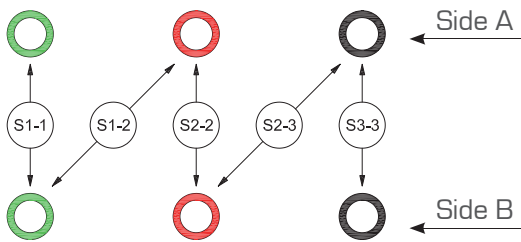

PT050 N configuration

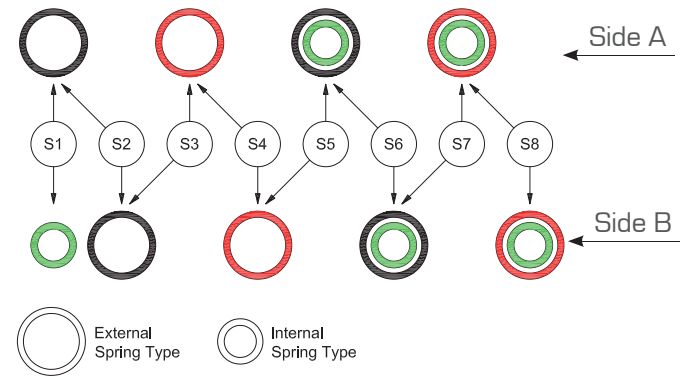

PT100 to PT1000 configuration

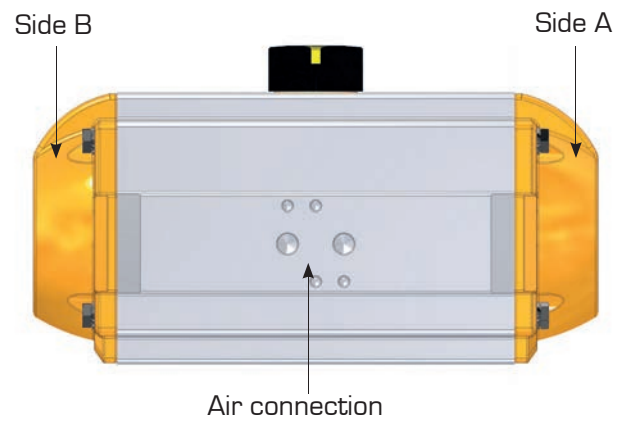
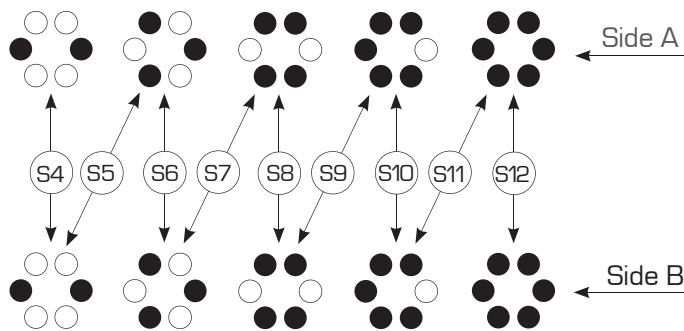

TYPICAL TORQUE CURVES FOR RACK PINION ACTUATORS

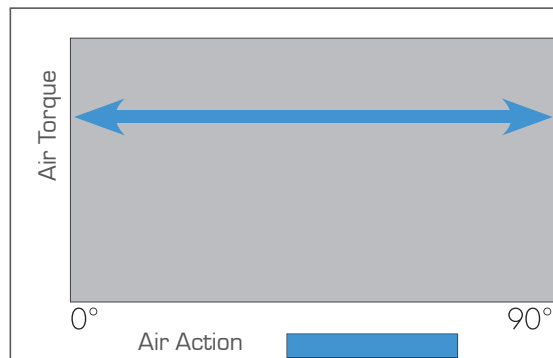

Torque output double acting

The double acting actuator has constant torque over the whole stroke. So, that all that needs to be known for sizing is the maximum valve torque, which is multiplied by a safety factor (usually at least 25% - 30% depending on the valve and service).

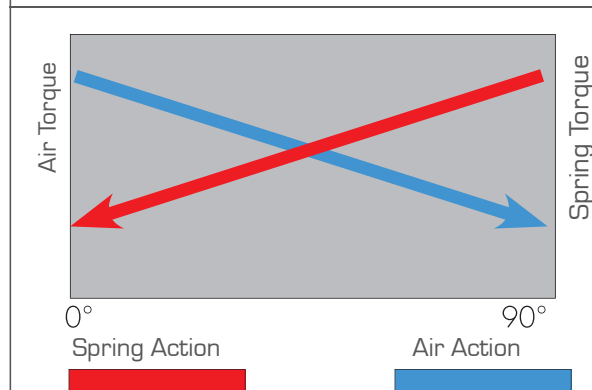

Torque output spring return

The spring return actuator has four different torque values: the air torques at 0° and 90° when it is pressurized, and the spring torques at 90° and 0° when the pressure is discharged. For a correct sizing, the torque curves of the actuator in both strokes have to be higher than the valve torque curves. Also for the spring return actuator sizing, the valve torques have to be multiplied by a safety factor (usually at least 25%-30% depending on the valve and service). The PT "N" Series are designed to give a balanced torque when the number of springs per side is equal to the air pressure supply in bar (for example 4 bar, 4 springs per side).

DIMENSIONS AND TECHNICAL DATA

DIMENSIONS IN MM

ACTUATOR MODEL	PT045 D/S	PT050 N D/S	PT100 D/S	PT200 D/S	PT250 D/S	PT300 D/S	PT350 D/S	PT400 D/S	PT450 D/S	PT500 D/S	PT550 D/S	PT600 D/S	PT650 D/S	PT700 D/S	PT750 D/S	PT800 D/S	PT1000 D/S
A	118	137	154	204	241	259	304	333	395	423	473	528	605	710	812	855	950
B	66	69	85	102	115	127	145	157	177	196	220,5	245	298,5	330	383	410	518
C	62	78,5	91,5	105	118,5	130,5	148,5	159	182,5	200,5	223	244,5	284	319	371	418	528
D	M5x8	M5x8	M5x8	M5x8	M5x8	M5x8	M5x8	M5x8	M5x8	M5x8	M5x8	M5x8	M6x10	M6x10	M6x10	M6x10	M6x10
E	M5x8	M5x8	M5x8	M5x8	M5x8	M5x8	M5x8	M5x8	M5x8	M5x8	M5x8	M5x8	M5x8	M5x8	M5x8	M5x8	M6x10
F	80	80	80	80	80	80	80	80	80	80	130	130	130	130	130	130	200
G	30	30	30	30	30	30	30	30	30	30	30	30	30	30	30	30	50
N	11	11	11	17	17	17	27	27	27	27	36	36	36	36	36	36	36
P	15 / 20	20	20	20	20	20	30	30	30	30	50	50	50	50	50	50	80
R	32	32	32	32	32	32	32	32	32	32	32	32	45	45	45	45	45
S	24	24	24	24	24	24	24	24	24	24	24	24	40	40	40	40	40
T NPT	1/8"	1/8"	1/8"	1/8"	1/8"	1/8"	1/4"	1/4"	1/4"	1/4"	1/4"	1/4"	3/8"	1/2"	1/2"	1/2"	1/2"
aZ1	40	40	40	40	40	40	65	65	65	65	65	65	115	115	115	115	115
ISO Flange	F04	F04	F05 + F07	F05 + F07	F05 + F07	F07 + F10	F07 + F10	F07 + F10	F10 + F12	F10 + F12	F14	F14	F16	F16	F16	F16 + F25	F16 + F25 + F30
Q	42	42	50	50	50	70	70	70	102	102	140	140	165	165	165	165	165
Q1	-	-	70	70	70	102	102	102	125	125	-	-	-	-	-	254	254
Q2	-	-	-	-	-	-	-	-	-	-	-	-	-	-	-	-	298
W	M5	M5	M6	M6	M6	M8	M8	M8	M10	M10	M16	M16	M20	M20	M20	M20	M20
W1	-	-	M8	M8	M8	M10	M10	M10	M12	M12	-	-	-	-	-	M16	M16
W2	-	-	-	-	-	-	-	-	-	-	-	-	-	-	-	-	M20

Typical Connection for protection "L"

CH x I min	SQ	-	9 x 10	11 x 12	14 x 16	17 x 19	17 x 19	22 x 24	22 x 24	27 x 29	27 x 29	27 x 29	36 x 38	-	-	-	-	-
	DS	11 x 12	-	-	-	-	-	-	-	-	-	-	-	46 x 48	46 x 48	55 x 57	55 x 57	75 x 77

Typical Connection for protection "A", "E", "H" and "M"

CH x I min	DS	11 x 12	11 x 12	14 x 16	17 x 19	17 x 19	22 x 24	22 x 24	22 x 24	27 x 29	27 x 29	36 x 38	36 x 38	46 x 48	46 x 48	46 x 48	55 x 57	55 x 57
------------	----	---------	---------	---------	---------	---------	---------	---------	---------	---------	---------	---------	---------	---------	---------	---------	---------	---------

OPTIONAL ISO Flange	F03	F03 + F05	F04 + F07	-	-	-	-	-	-	-	F12	F12	F14	-	-	F16 + F25	-	-
CH x I min	DS	9 x 10	-	-	-	-	17 x 19	17 x 19	27 x 29	22 x 24	-	27 x 29	27 x 29	36 x 38	-	-	-	-

Technical data (Metric Unit)

METRIC	MODEL TYPE	PT045		PT050 N		PT100		PT200		PT250		PT300		PT350		PT400		PT450		PT500		PT550		PT600		PT650		PT700		PT750		PT800		PT1000	
		D	S	D	S	D	S	D	S	D	S	D	S	D	S	D	S	D	S	D	S	D	S	D	S	D	S	D	S	D	S	D	S		
Opening Time (Sec.)		0,15	0,2	0,2	0,25	0,25	0,3	0,3	0,4	0,4	0,5	0,5	0,7	0,7	0,9	0,9	1,2	1,2	1,5	1,5	1,8	2	2,4	2,7	3,5	3,5	4,1	4	4,5	5	6	6	7,5	8	10
Closing Time (Sec.)		0,2	0,25	0,25	0,3	0,3	0,35	0,35	0,5	0,5	0,6	0,6	0,9	0,8	1,1	1,1	1,4	1,4	1,8	1,7	2,1	2,2	2,8	3,2	4	4	4,6	4,5	5	6	7	7	8,5	9	11
Air Volume Opening (L)		0,06		0,09		0,16		0,31		0,51		0,71		1,19		1,54		2,41		3,14		4,26		5,94		10		14,5		20		25		49	
Air Volume Closing (L)		0,1		0,15		0,26		0,49		0,78		1,11		1,80		2,34		3,78		4,92		6,89		9,46		15,2		21,4		33		40		84	
Approximate Weight (Kg)		0,75	0,9	1,15	1,26	1,7	1,9	3,0	3,4	4,2	4,8	5,7	6,6	8,8	10,2	10,7	12,6	15,5	18,7	19,6	23,7	25	33	37	45	56	71	77	97	118	150	127	169	170	238



Note: [A] The above moving times of the actuator are obtained in the following test conditions:

For models PT045 + PT500 : [1] Room Temperature, [2] Actuator Stroke 90°, [3] Solenoid Valve with Orifice Of 4 mm and a flow capacity Gn 400L/min., [4] Inside pipe diameter 8 mm, [5] Medium clean air, [6] Air supply pressure 5,5 bar [79,75 Psi], [7] Actuator without external resistance load.

For models PT550 + PT1000 : [1] Room Temperature, [2] Actuator Stroke 90°, [3] Solenoid Valve with Orifice Of 11 mm and a flow capacity Gn 6000L/min., [4] Inside pipe diameter 11 mm, [5] Medium clean air, [6] Air supply pressure 5,5 bar [79,75 Psi], [7] Actuator without external resistance load.

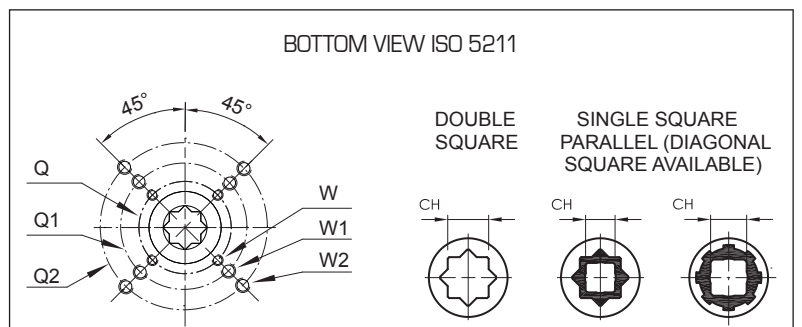
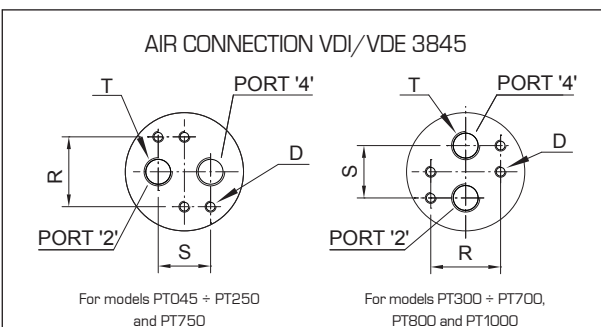
Cautions: obviously on the field applications when one or more of the above parameter are different, the moving time will be different.

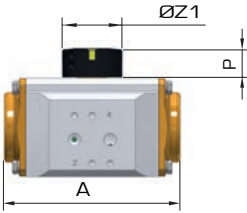
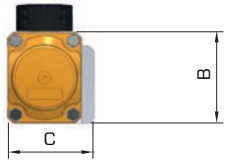
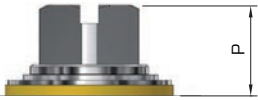
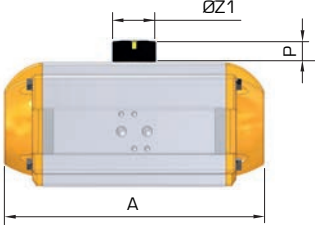
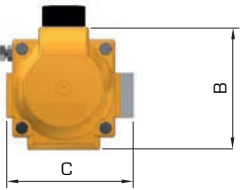

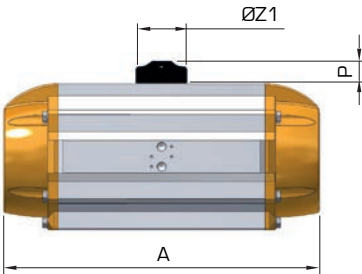
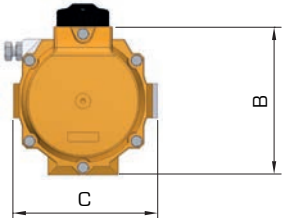
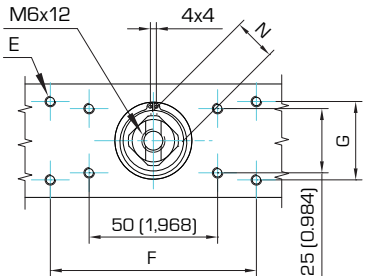
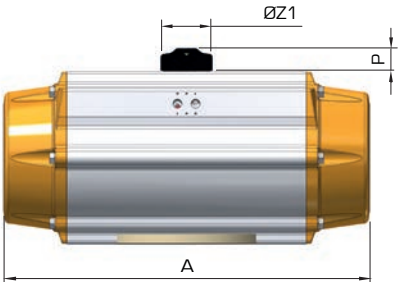
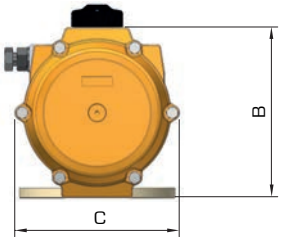
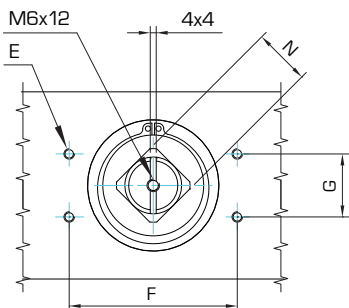
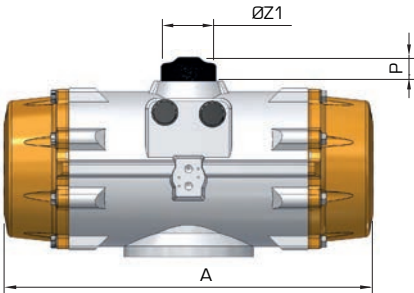
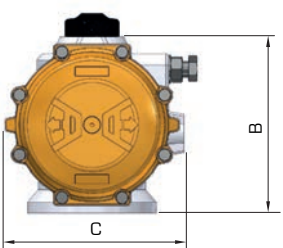
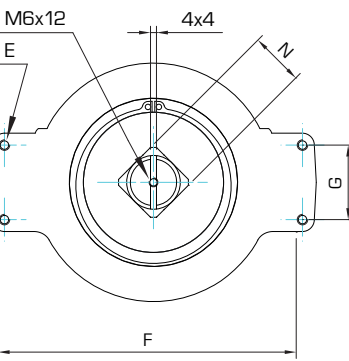
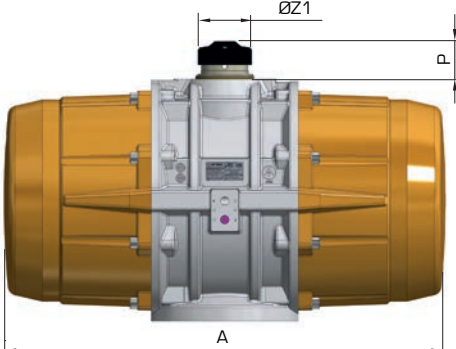
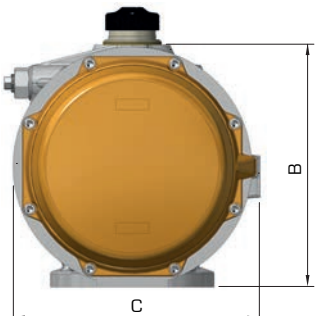
	FRONT VIEW	SIDE VIEW	TOP DETAIL
PT045			<p>PT045 ÷ PT100</p> 
PT050 N ÷ PT650			<p>PT200 ÷ PT1000</p> 
PT700			<p>PT045</p> 
PT750			<p>PT050 N ÷ PT750</p> 
PT800			<p>PT800 ÷ PT1000</p> 
PT1000			

DIMENSIONS AND TECHNICAL DATA

Dimensions in inch

ACTUATOR MODEL	PT045 D/S	PT050 N D/S	PT100 D/S	PT200 D/S	PT250 D/S	PT300 D/S	PT350 D/S	PT400 D/S	PT450 D/S	PT500 D/S	PT550 D/S	PT600 D/S	PT650 D/S	PT700 D/S	PT750 D/S	PT800 D/S	PT1000 D/S	
A	4,65	5,39	6,06	8,03	9,49	10,20	11,97	13,11	15,55	16,65	18,62	20,79	23,82	27,95	31,97	33,66	37,40	
B	2,60	2,72	3,35	4,02	4,53	5,00	5,71	6,18	6,97	7,72	8,68	9,65	11,75	12,99	15,08	16,14	20,39	
C	2,44	3,09	3,60	4,13	4,67	5,14	5,85	6,26	7,19	7,89	8,78	9,63	11,18	12,56	14,61	16,46	20,79	
D	10-24UNC x0,31	10-24UNC x0,31	10-24UNC x0,31	10-24UNC x0,31	10-24UNC x0,31	10-24UNC x0,31	10-24UNC x0,31	10-24UNC x0,31	10-24UNC x0,31	10-24UNC x0,31	10-24UNC x0,31	10-24UNC x0,31	10-24UNC x0,31	1/4-20UNC x0,39	1/4-20UNC x0,39	1/4-20UNC x0,39	1/4-20UNC x0,39	
E	10-24UNC x0,31	10-24UNC x0,31	10-24UNC x0,31	10-24UNC x0,31	10-24UNC x0,31	10-24UNC x0,31	10-24UNC x0,31	10-24UNC x0,31	10-24UNC x0,31	10-24UNC x0,31	10-24UNC x0,31	10-24UNC x0,31	10-24UNC x0,31	10-24UNC x0,31	10-24UNC x0,31	10-24UNC x0,31	1/4-20UNC x0,39	
F	3,15	3,15	3,15	3,15	3,15	3,15	3,15	3,15	3,15	3,15	5,12	5,12	5,12	5,12	5,12	5,12	7,87	
G	1,18	1,18	1,18	1,18	1,18	1,18	1,18	1,18	1,18	1,18	1,18	1,18	1,18	1,18	1,18	1,18	1,97	
N	0,43	0,43	0,43	0,67	0,67	0,67	1,06	1,06	1,06	1,06	1,42	1,42	1,42	1,42	1,42	1,42	1,42	
P	0,59 / 0,79	0,79	0,79	0,79	0,79	0,79	1,18	1,18	1,18	1,18	1,97	1,97	1,97	1,97	1,97	1,97	3,15	
R	1,26	1,26	1,26	1,26	1,26	1,26	1,26	1,26	1,26	1,26	1,26	1,26	1,26	1,77	1,77	1,77	1,77	
S	0,94	0,94	0,94	0,94	0,94	0,94	0,94	0,94	0,94	0,94	0,94	0,94	0,94	1,57	1,57	1,57	1,57	
T NPT	1/8"	1/8"	1/8"	1/8"	1/8"	1/4"	1/4"	1/4"	1/4"	1/4"	1/4"	1/4"	1/4"	3/8"	1/2"	1/2"	1/2"	1/2"
aZ1	1,57	1,57	1,57	1,57	1,57	1,57	2,56	2,56	2,56	2,56	2,56	2,56	4,53	4,53	4,53	4,53	4,53	
ISO Flange	F04	F04	F05 + F07	F05 + F07	F05 + F07	F07 + F10	F07 + F10	F07 + F10	F10 + F12	F10 + F12	F14	F14	F16	F16	F16	F16 + F25	F16 + F25 + F30	
Q	1,65	1,65	1,97	1,97	1,97	2,76	2,76	2,76	4,02	4,02	5,51	5,51	6,50	6,50	6,50	6,50	6,50	
Q1	-	-	2,76	2,76	2,76	4,02	4,02	4,02	4,92	4,92	-	-	-	-	-	-	10	
Q2	-	-	-	-	-	-	-	-	-	-	-	-	-	-	-	-	11,73	
W	10-24UNC x0,31	10-24UNC x0,31	1/4-20UNC x0,35	1/4-20UNC x0,35	1/4-20UNC x0,35	5/16-18UNC x0,47	5/16-18UNC x0,47	5/16-18UNC x0,47	3/8-16UNC x0,59	3/8-16UNC x0,59	5/8-11UNC x0,94	5/8-11UNC x0,94	3/4-10UNC x1,18	3/4-10UNC x1,18	3/4-10UNC x1,18	3/4-10UNC x1,18	5/8-11UNC x0,94	
W1	-	-	5/16-18UNC x0,47	5/16-18UNC x0,47	5/16-18UNC x0,47	3/8-16UNC x0,59	3/8-16UNC x0,59	3/8-16UNC x0,59	1/2-13UNC x0,71	1/2-13UNC x0,71	-	-	-	-	-	-	3/4-10UNC x1,18	
W2	-	-	-	-	-	-	-	-	-	-	-	-	-	-	-	-	3/4-10UNC x1,18	

Typical Connection for protection "L"

CH x I min	SQ	DS	0,35x0,39	0,43x0,47	0,55x0,63	0,67x0,75	0,67x0,75	0,87x0,94	0,87x0,94	1,06x1,14	1,06x1,14	1,06x1,14	1,42x1,5	-	-	-	-	-
			0,43x0,47	-	-	-	-	-	-	-	-	-	-	1,81x1,89	1,81x1,89	2,17x2,24	2,17x2,24	2,95x3,03

Typical Connection for protection "A", "E", "H" and "M"

CH x I min	DS	0,43x0,47	0,43x0,47	0,55x0,63	0,67x0,75	0,67x0,75	0,87x0,94	0,87x0,94	0,87x0,94	1,06x1,14	1,06x1,14	1,42x1,5	1,42x1,5	1,81x1,89	1,81x1,89	1,81x1,89	2,17x2,24	2,17x2,24
		0,43x0,47	0,43x0,47	0,55x0,63	0,67x0,75	0,67x0,75	0,87x0,94	0,87x0,94	0,87x0,94	1,06x1,14	1,06x1,14	1,42x1,5	1,42x1,5	1,81x1,89	1,81x1,89	1,81x1,89	2,17x2,24	2,17x2,24

OPTIONAL ISO Flange	F03 + F05	F04 + F07	-	-	-	-	-	-	-	-	F12	F12	F14	-	-	F16 + F25	-	-	
CH x I min	DS	0,35x0,39	-	-	-	-	0,67x0,75	0,67x0,75	1,06x1,14	0,87x0,94	-	1,06x1,14	1,06x1,14	1,42x1,5	-	-	-	-	-

Technical data (Imperial Unit)

IMPERIAL	MODEL TYPE	PT045 D S	PT050 N D S	PT100 D S	PT200 D S	PT250 D S	PT300 D S	PT350 D S	PT400 D S	PT450 D S	PT500 D S	PT550 D S	PT600 D S	PT650 D S	PT700 D S	PT750 D S	PT800 D S	PT1000 D S
Opening Time	(Sec.)	0,15 0,2	0,2 0,25	0,25 0,3	0,3 0,4	0,4 0,5	0,5 0,7	0,7 0,9	0,9 1,2	1,2 1,5	1,5 1,8	2 2,4	2,7 3,5	3,5 4,1	4 4,5	5 6	6 7,5	8 10
Closing Time	(Sec.)	0,2 0,25	0,25 0,3	0,3 0,35	0,35 0,5	0,5 0,6	0,6 0,9	0,8 1,1	1,1 1,4	1,4 1,8	1,7 2,1	2,2 2,8	3,2 4	4 4,6	4,5 5	6 7	7 8,5	9 11
Air Volume Opening	(Cu. In.)	3,66	5,5	9,8	18,9	31,1	43,3	72,6	94	147,1	191,6	260	362,5	610,2	884,8	1220	1526	2990
Air Volume Closing	(Cu. In.)	6,1	9,2	15,9	29,9	47,6	67,7	109,8	142,8	230,7	300,2	420,5	577,3	927,6	1305	2014	2441	5126
Approximate Weight	(Lbs)	1,65 1,98	2,5 2,8	3,8 4,2	6,5 7,4	9,3 10,6	12,6 14,6	19,4 22,5	23,6 27,8	34,2 41,2	43,2 52,2	55,1 72,8	81,6 99,2	123 157	170 215	260 331	280 371	375 525

Note: (A) The above moving times of the actuator are obtained in the following test conditions:

For models PT045 + PT500 : (1) Room Temperature, (2) Actuator Stroke 90°, (3) Solenoid Valve with Orifice Of 4 mm and a flow capacity Gn 400L/min., (4) Inside pipe diameter 8 mm, (5) Medium clean air, (6) Air supply pressure 5,5 bar (79,75 Psi), (7) Actuator without external resistance load.

For models PT550 + PT1000 : (1) Room Temperature, (2) Actuator Stroke 90°, (3) Solenoid Valve with Orifice Of 11 mm and a flow capacity Gn 6000L/min., (4) Inside pipe diameter 11 mm, (5) Medium clean air, (6) Air supply pressure 5,5 bar (79,75 Psi), (7) Actuator without external resistance load.

Cautions: obviously on the field applications when one or more of the above parameter are different, the moving time will be different.

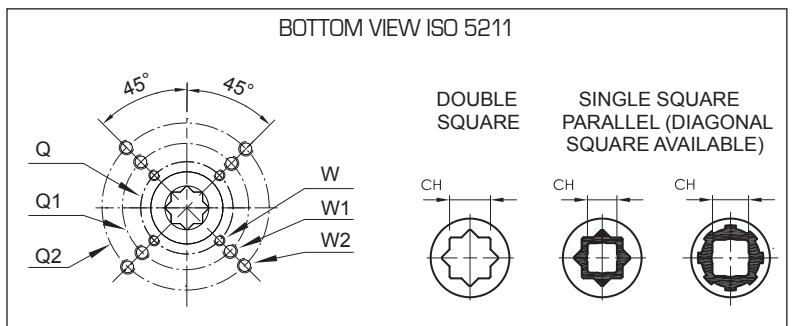
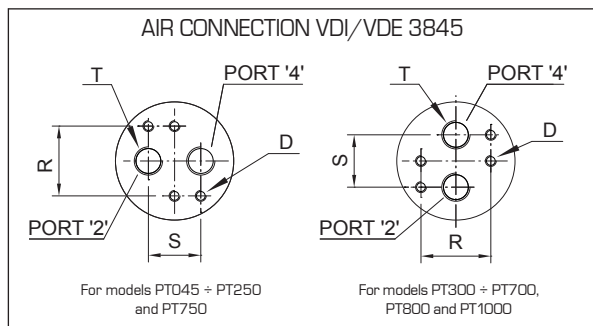

PARTS AND MATERIALS

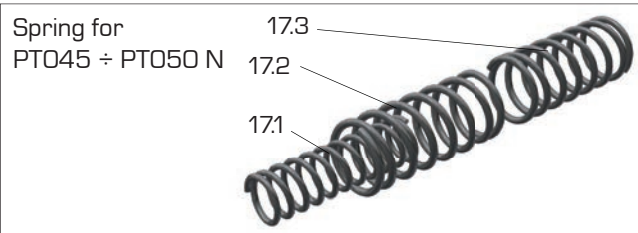
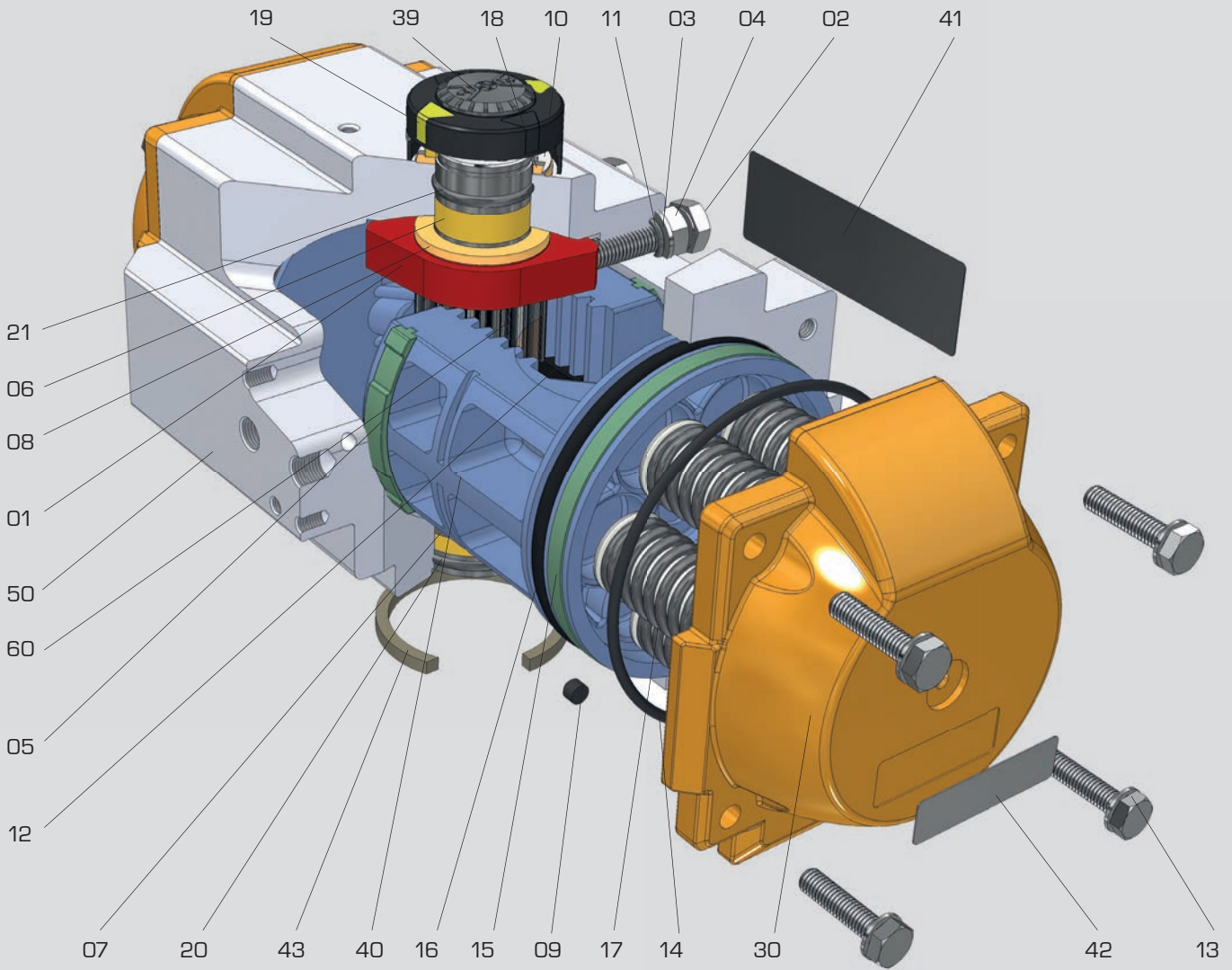

PART N°	Spare Parts	UNIT Q.TY / NOTE	PART DESCRIPTION	STANDARD MATERIAL
01		1 NA for PT045	OCTI-CAM (Stop arrangement)	Stainless Steel (only for PT050 N ÷ PT300) Carbon Steel / Nodular Cast Iron, zinc coated
02		2 NA for PT045	STOP CAP SCREW	Stainless Steel
02.1		2 only for PT1000	SPRING CLIP (Anti-blowout stop screw)	Stainless Steel
03		2 NA for PT045	WASHER	Stainless Steel
04		2 NA for PT045	NUT (Stop screw)	Stainless Steel
05	○	2 for PT1000	BEARING (Piston back)	High-grade polymers
06	○	1	BEARING (Pinion top)	High-grade polymers
07	○	1	BEARING (Pinion bottom)	High-grade polymers
08	○	2 1 pc. for PT045	THRUST BEARING (Pinion)	High-grade polymers
09	○ □	2	PLUG	M-NBR / Silicone
09.1	○ □	2 for PT800 ÷ PT1000	"O" RING PLUG	M-NBR / Silicone
10		1	THRUST WASHER (Pinion)	Stainless Steel
11	○ □	2 NA for PT045	"O" RING (Stop screw)	M-NBR
12		2 NA for PT045	PISTON GUIDE	High-grade polymers

○ Parts included in Complete spare parts kit - □ Parts included in "O" ring spare parts kit

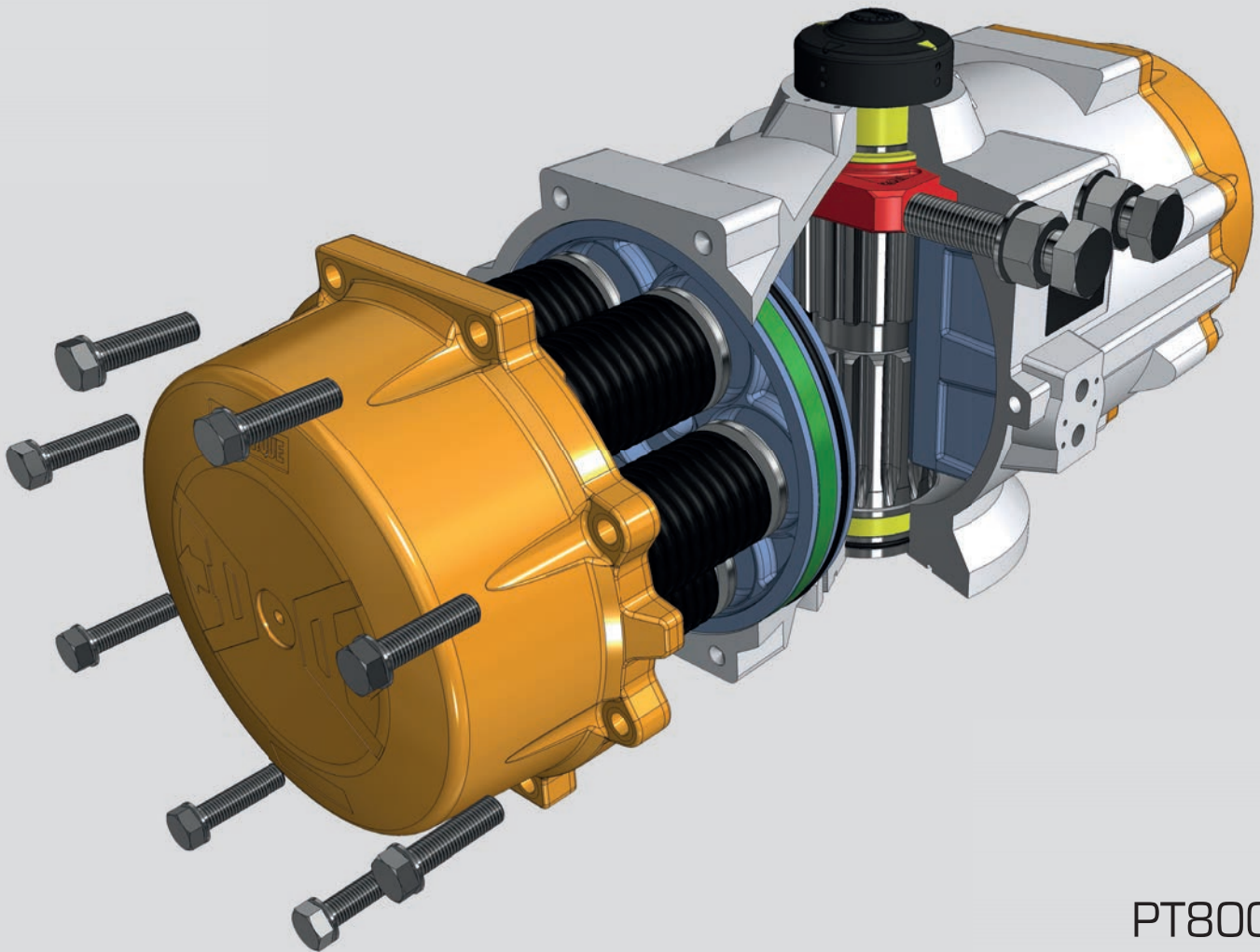

PT800

PART N°	Spare Parts	UNIT Q.TY / NOTE	PART DESCRIPTION	STANDARD MATERIAL
13		8 for PT045 ÷ PT650	CAP SCREW (End cap)	Stainless Steel
		12 for PT700 ÷ PT750		
		16 for PT800 ÷ PT1000		
13.1		16 for PT1000	WASHER (Cap Screw end cap)	Stainless Steel
14	○ □	2	"O" RING (End cap)	M-NBR
15	○	2	BEARING (Piston head)	High-grade polymers
16	○ □	2	"O" RING (Piston)	M-NBR
17		max. 12 for PT100 ÷ PT1000	SPRING (Cartridge)	SiCr Spring alloy Steel coated
17.1			SPRING	
17.2		max. 2 only for PT045	SPRING	
17.3		max. 4 only for PT050 N	SPRING	
18		1	SPRING CLIP (Pinion)	Spring Steel, ENP
19		1	POSITION INDICATOR	High-grade polymers
20	○ □	1	"O" RING (Pinion bottom)	M-NBR

○ Parts included in Complete spare parts kit - □ Parts included in "O" ring spare parts kit

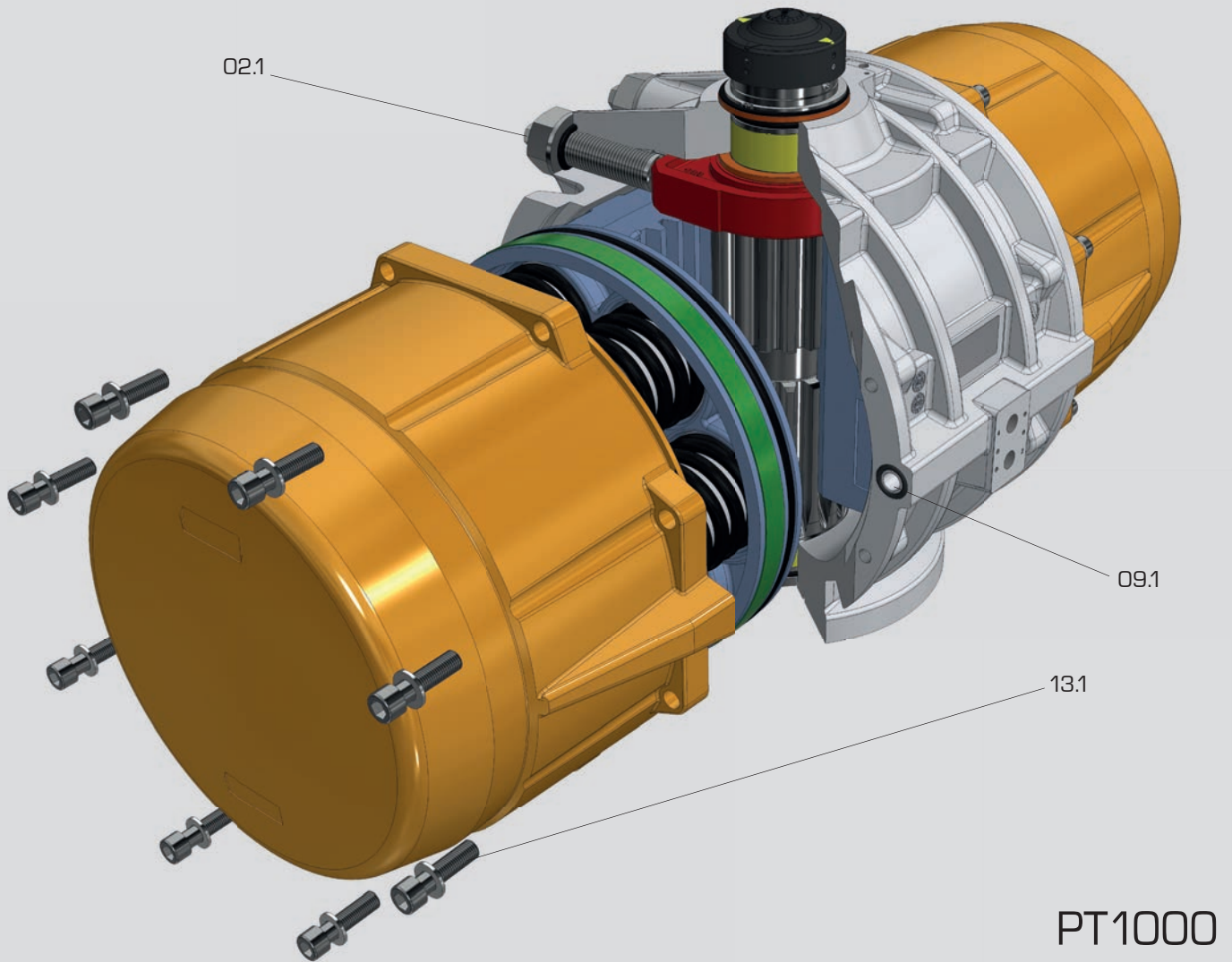

PT1000

PART N°	Spare Parts	UNIT Q.TY / NOTE	PART DESCRIPTION	STANDARD MATERIAL
21	○ □	1	"O" RING (Pinion top)	M-NBR
30		2	END CAP	Pressure Die Cast Aluminium alloy, anodized and coated Cast Aluminium alloy, anodized and coated (for PT1000)
39		1 for PT045 ÷ PT300	CAP SCREW (Indicator)	High-grade polymers
40		2	PISTON	Pressure Die Cast Aluminium alloy, anodized Cast Aluminium alloy, anodized (for PT1000)
41		1	ACTUATOR IDENTIFICATION LABEL	Polyester-Silver
42		2	END CAP LABEL	Polyester-Silver
43		1	SPIGOT (Only on request)	Extruded Aluminium alloy, anodized
50		1	BODY	Extruded Aluminium alloy, coated Cast Aluminium alloy, coated (for PT800 and PT1000)
60		1	INTEGRAL DRIVE SHAFT	Extruded Aluminium alloy, anodized (for PT045 and PT1000) Steel, ENP

○ Parts included in Complete spare parts kit - □ Parts included in "O" ring spare parts kit

TORQUE OUTPUT (Nm)

SPRING RETURN TORQUE

Model	Spring set	2,5 bar		3 bar		3,5 bar		4 bar		4,2 bar		4,5 bar		5 bar		5,5 bar		6 bar		7 bar		8 bar		Spring stroke					
		0°	90°	0°	90°	0°	90°	0°	90°	0°	90°	0°	90°	0°	90°	0°	90°	0°	90°	0°	90°	0°	90°	90°	0°				
		Start	End	Start	End	Start	End	Start	End	Start	End	Start	End	Start	End	Start	End	Start	End	Start	End	Start	End	Start	End				
PT045	S 1-1	4,3	2,9																						3,1	1,7			
	S 1-2			4,7	2,4																					4,8	2,6		
	S 2-2					4,9	2,0			6,1	3,2			6,6	3,7											6,4	3,5		
	S 2-3												6,6	2,8			7,8	4,0	9,0	5,2	10,2	6,4				8,0	4,2		
	S 3-3																8,2	3,6	9,4	4,8		11,8	7,2	14,1	9,5		9,6	5,0	
PT050 N	S 1	5,0	3,0	7	4,7	8	6,3	10,0	8	9,4	8,3	11,7	9,6	13,3	11,3												5,3	3,3	
	S 2	4	1,9	6,0	3,6	7,7	5,3	9,3	6,9	9	7,4	11,0	8,6	12,7	10,2	14,3	11,9										6,4	4,0	
	S 3			5,3	2,5	7,0	4,2	8,7	5,8	8,2	6,6	10,3	7,5	12,0	9,2	13,7	10,8	15,3	12,5								7,4	4,6	
	S 4					6,3	3	8,0	5	8,7	5,5	9,7	6,4	11,3	8,1	13,0	9,8	14,7	11,4		18,0	14,7					8,5	5,3	
	S 5							7,3	3,7	7,0	4,9	9,0	5,4	10,7	7,0	12,3	8,7	14,0	10	17,3	13,7	20,6	17,0				9,6	5,9	
	S 6													8,4	4,3	10,0	6,0	11,7	7,6	13,3	9,3	16,7	12,6	20,0	16		10,6	6,6	
	S 7															11	6,6	13	8,2	16,0	11,6	19,3	14,9				11,7	7,3	
	S 8															10,4	6	12,0	7,2	15,3	10,5	18,7	13,8				12,8	7,9	
PT100	S 05	9,1	6,2	12	9,2	15	12,1	17,9	15	19,1	16,2	20,8	17,9	23,8	20,9												8,4	5,5	
	S 06	8	4,5	10,9	7,5	13,9	10,4	16,8	13,3	18	14,5	19,7	16,3	22,7	19,2	25,6	22,1										10,1	6,7	
	S 07			9,8	5,8	12,8	8,7	15,7	11,6	16,9	12,8	18,6	14,6	21,5	17,5	24,5	20,4	27,4	23,4								11,8	7,8	
	S 08					11,6	7	14,6	10	15,7	11,8	17,5	12,9	20,4	15,8	23,4	18,7	26,3	21,7	32,2	27,5						13,5	8,9	
	S 09							13,5	8,3	14,6	9,4	16,4	11,2	19,3	14,1	22,3	17,1	25,2	20	31,1	25,9	36,9	31,7				15,2	10	
	S 10												15,3	9,5	18,2	12,4	21,1	15,4	24,1	18,3	29,9	24,2	35,8	30			16,9	11,1	
	S 11														17,1	10,8	20	13,7	23	16,6	28,8	22,5	34,7	28,3				18,6	12,2
	S 12															18,9	12	21,9	14,9	27,7	20,8	33,6	26,7				20,2	13,3	
	S 05	16	11,8	23,8	17,6	29,7	23,4	35,5	29,2	37,8	31,6	41,3	35	47,1	40,9													17,3	11,1
	S 06	15,8	8,3	21,6	14,1	27,5	19,9	33,3	25,8	35,6	28,1	39,1	31,6	44,9	37,4	50,7	43,2											21	13,3
	S 07			19,4	10,7	25,2	16,5	31,1	22,3	33,4	24,6	36,9	28,1	42,7	33,9	48,5	39,8	54,3	45,6									24,2	15,5
	S 08					23	13	28,8	18,8	31,2	21,2	34,7	24,7	40,5	30,5	46,3	36,3	52,1	42,1	63,7	53,7							27,7	17,7
S 09							26,6	15,4	29	17,7	32,5	21,2	38,3	27	44,1	32,8	49,9	38,6	61,5	50,3	73,2	61,9				31	19,9		
S 10													30,2	17,7	36,1	23,6	41,9	29,4	47,7	35,2	59,3	46,8	71	58,5			34,6	22,1	
S 11															33,8	20,1	39,7	25,9	45,5	31,7	57,1	43,4	68,7	55			38,1	24,3	
S 12																37,5	22,4	43,3	28,3	54,9	39,9	66,5	51,5				41,5	26,5	
PT200	S 05	27,4	16,9	36,6	26	45,7	35,2	54,9	44,3	58,5	48	64	53,5	73,2	62,6												28,9	18,3	
	S 06	23,8	11,1	32,9	20,3	42,1	29,4	51,2	38,6	54,9	42,2	60,4	47,7	69,5	56,9	78,7	66										34,7	22	
	S 07			29,2	14,5	38,4	23,6	47,5	32,8	51,2	36,4	56,7	41,9	65,8	51,1	75	60,2	84,2	69,4								40,4	25,7	
	S 08					34,7	17,9	43,9	27	47,5	30,7	53	36,2	62,2	45,3	71,3	54,5	80,5	63,6	98,8	81,9						46,2	29,3	
	S 09							40,2	21,2	43,9	24,9	49,4	30,4	58,5	39,5	67,7	49	76,8	57,8	95,1	76,1	113	94,5				52	33	
	S 10											45,7	24,6	54,8	33,8	64	42,9	73,1	52,1	91,5	70,4	110	88,7				57,8	36,7	
	S 11													51,2	28	60,3	37,1	69,5	46,3	87,8	64,6	106	82,9				63,5	40,3	
	S 12															56,7	31,4	65,8	40,5	84,1	58,8	102	77,1				69,3	44	
PT250	S 05	41,1	27,1	54,4	40,4	67,7	53,7	81	67	86,3	72,3	94,3	80,3	108	93,6												39,4	25,3	
	S 06	36,1	19,2	49,4	32,5	62,7	45,8	76	59,1	81,3	64,4	89,3	72,4	103	85,7	116	99										47,3	30,4	
	S 07			44,3	24,6	57,6	37,9	70,9	51,2	76,2	56,5	84,2	64,5	97	77,8	111	91,1	124	104								55,1	35,5	
	S 08					52,5	30	65,8	43,3	71,1	48,7	79,1	56,6	92,4	69,9	106	83,2	119,0	96,5	146	123						63	40,5	
	S 09							60,8	35,5	66,1	40,8	74,0	48,8	87,3	62,1	101	75,3	113,9	88,6	141	115	167	142				70,9	45,6	
	S 10											69	40,9	82,3	54,2	95,6	67,5	109	80,8	135	107	162	134				78,8	50,7	
	S 11													77,2	46,3	90,5	59,6	104	72,9	130	99	157	126				86,7	55,7	
	S 12															85,4	51,7	99	65	125	92	152	118				94,5	60,8	
PT300	S 05	66,5	41,9	87,9	63,4	109,4	84,9	131	106	140	115	152	128	174	149												65,5	41	
	S 06	58,3	28,8	79,7	50,3	101,2	71,8	123	93,3	131	102	144	115	166	136	187	158										78,6	49,2	
	S 07			71,5	37,2	93	58,7	115	80,2	123	88,8	136	102	158	123	179	145	200	166								91,7	57,4	
	S 08					84,8	45,6	106	67,1	115	75,7	128	88,6	149	110	171	132	192	153	235	196						105	65,6	
	S 09							98,1	54	107	62,6	120	75	141	97	163	118	184	140	227	183	270	226				118	73,8	
	S 10											111	62,4	133	83,9	154	105	176	127	219	170	262	213				131	82	
	S 11													125	70,8	146	92,3	168	114	211	157	254	200				144	90,2	
	S 12															138	79,2	159	101	202	144	245	187				157	98,4	
PT400	S 05	86	56,1	114	83,8	141	111	169	139	180	150	197	167	224	195												82,4	52,5	
	S 06	75,5	39,6	103	67,3	131	95,0	159	123	170	134	186	150	214	178	242	206										98,9	63	
	S 07			92,7	50,8	120	78,5	148	106	159	117	176	134	203	162	231	189	259	217								115	73,5	
	S 08					110	62	138	89,7	149	101	165	117	193	145	221	173	248											

TORQUE OUTPUT (Nm)

SPRING RETURN TORQUE

Model	Spring set	2,5 bar		3 bar		3,5 bar		4 bar		4,2 bar		4,5 bar		5 bar		5,5 bar		6 bar		7 bar		8 bar		Spring stroke	
		0°	90°	0°	90°	0°	90°	0°	90°	0°	90°	0°	90°	0°	90°	0°	90°	0°	90°	0°	90°	0°	90°	Start	End
		Start	End	Start	End	Start	End	Start	End	Start	End	Start	End	Start	End	Start	End	Start	End	Start	End	Start	End	Start	End
PT600	S 05	319	217	426	323	532	430	638	536	681	578	745	642	851	749									315	213
	S 06	277	154	383	260	489	367	596	473	638	515	702	579	808	686	915	792							378	255
	S 07			341	197	447	304	553	410	596	453	660	516	766	623	872	729	979	835					441	298
	S 08					404	241	511	347	553	390	617	453	723	560	830	666	936	772	1149	985			504	340
	S 09							468	284	511	327	575	390	681	497	787	603	894	709	1106	922	1319	1135	567	383
	S 10											532	327	638	434	745	540	851	646	1064	859	1277	1072	630	425
	S 11													596	371	702	477	809	583	1021	796	1234	1009	683	468
	S 12															660	414	766	520	979	733	1192	946	756	510
PT650	S 05	533	372	712	551	890	730	1069	908	1141	980	1248	1087	1426	1266									521	360
	S 06	461	268	640	447	818	625	997	804	1068	876	1176	983	1354	1162	1533	1340							625	433
	S 07			568	343	746	521	925	700	996	771	1104	879	1282	1057	1461	1236	1640	1415					730	505
	S 08					674	417	853	596	924	667	1032	774	1210	953	1389	1132	1568	1310	1925	1668			834	577
	S 09							781	491	852	563	959	670	1138	849	1317	1028	1495	1206	1853	1564	2210	1921	938	649
	S 10											887	566	1066	745	1245	923	1423	1102	1781	1459	2138	1817	1042	721
	S 11													994	640	1173	819	1351	998	1709	1355	2066	1713	1146	793
	S 12															1101	715	1279	894	1637	1251	1994	1608	1251	865
PT700	S 05	751	496	1011	755	1270	1015	1529	1274	1633	1378	1789	1533	2048	1793									801	546
	S 06	642	336	902	595	1161	854	1420	1114	1524	1217	1680	1373	1939	1632	2198	1892							961	655
	S 07			792	435	1052	694	1311	954	1415	1057	1570	1213	1830	1472	2089	1732	2349	1931					1121	764
	S 08					943	534	1202	793	1306	897	1461	1053	1721	1312	1980	1571	2239	1831	2758	2350			1281	873
	S 09							1093	633	1197	737	1352	893	1612	1152	1871	1411	2130	1671	2649	2189	3168	2708	1442	982
	S 10											1243	732	1503	992	1762	1251	2021	1510	2540	2029	3059	2548	1602	1091
	S 11													1393	832	1653	1091	1912	1350	2431	1869	2950	2388	1762	1200
	S 12															1544	931	1803	1190	2322	1709	2840	2228	1922	1309
PT750	S 05	1064	703	1423	1062	1782	1421	2141	1780	2284	1924	2500	2139	2859	2498									1092	731
	S 06	918	485	1277	844	1636	1203	1995	1562	2138	1706	2354	1921	2713	2280	3072	2639							1310	877
	S 07			1131	626	1489	985	1848	1344	1992	1487	2207	1703	2566	2062	2925	2421	3284	2780					1528	1023
	S 08					1343	766	1702	1125	1846	1269	2061	1484	2420	1843	2779	2202	3138	2561	3856	3279			1746	1170
	S 09							1556	907	1700	1051	1915	1266	2274	1625	2633	1984	2992	2343	3710	3061	4428	3779	1965	1316
	S 10											1769	1048	2128	1407	2487	1766	2846	2125	3564	2843	4282	3560	2183	1462
	S 11													1982	1188	2341	1547	2700	1906	3418	2624	4135	3342	2401	1608
	S 12															2194	1329	2553	1688	3271	2406	3989	3124	2620	1754
PT800	S 05	1332	1014	1783	1465	2233	1915	2684	2365	2864	2546	3134	2816	3585	3266									1238	920
	S 06	1149	767	1599	1217	2049	1667	2500	2118	2680	2298	2950	2568	3401	3019	3851	3469							1486	1104
	S 07			1415	969	1865	1420	2316	1870	2496	2050	2766	2321	3217	2771	3667	3222	4118	3672					1733	1288
	S 08					1682	1172	2132	1623	2312	1803	2582	2073	3033	2524	3483	2974	3934	3424	4835	4325			1981	1472
	S 09							1948	1375	2128	1555	2398	1825	2849	2276	3299	2726	3750	3177	4651	4078	5551	4978	2229	1656
	S 10											2215	1578	2665	2028	3115	2479	3566	2929	4467	3830	5386	4731	2476	1839
	S 11													2481	1781	2931	2231	3382	2682	4283	3582	5184	4483	2724	2023
	S 12															2748	1983	3198	2434	4099	3335	5000	4236	2971	2207
PT1000	S 05	2474	1695	3308	2529	4142	3362	4976	4196	5310	4530	5810	5030	6644	5864									2475	1695
	S 06	2135	1200	2969	2034	3803	2867	4637	3701	4971	4035	5471	4535	6305	5369	7139	6203							2970	2034
	S 07			2630	1539	3464	2373	4298	3206	4632	3540	5132	4040	5966	4874	6800	5708	7633	6542					3465	2373
	S 08					3125	1878	3959	2711	4292	3045	4793	3545	5627	4379	6461	5213	7294	6047	8962	7715			3960	2712
	S 09							3620	2217	3953	2550	4454	3050	5288	3884	6122	4718	6955	5552	8623	7220	10291	8887	4455	3051
	S 10											4115	2555	4949	3389	5783	4223	6616	5057	8284	6725	9952	8393	4949	3390
	S 11													4610	2894	5444	3728	6277	4562	7945	6230	9613	7898	5444	3729
	S 12															5105	3233	5938	4067	7606	5735	9274	7403	5939	4068
Spring set	The above value are the out-put torque that remain available to operate the valve when the port "2" is pressurized																						Out-put torque available when air supply fails		

DOUBLE ACTING TORQUE

Supply Pressure	2,5 bar	3 bar	3,5 bar	4 bar	4,2 bar	4,5 bar	5 bar	5,5 bar	6 bar	7 bar	8 bar
PT045 D	6,0	7,2	8,4	9,6	10,1	10,8	12,0	13,2	14,4	16,8	19,1
PT050 N D	8,3	10,0	11,6	13,3	14,0	15,0	16,6	18,3	19,9	23,3	26,6
PT100 D	14,7	17,6	20,5	23,5	24,6	26,4	29,3	32,2	35,2	41,0	46,9
PT200 D	29,1	34,9	40,7	46,5	48,9	52,4	58,2	64,0	69,8	81,4	

TORQUE OUTPUT (Lb-In)

SPRING RETURN TORQUE

Supply Pressure		40 Psi		50 Psi		60 Psi		70 Psi		80 Psi		90 Psi		100 Psi		110 Psi		116 Psi		Spring stroke				
Model	Spring set	0°	90°	0°	90°	0°	90°	0°	90°	0°	90°	0°	90°	0°	90°	0°	90°	0°	90°	90°	0°			
		Start	End	Start	End	Start	End	Start	End	Start	End	Start	End	Start	End	Start	End	Start	End	Start	End			
PT045	S 1-1	43.3	30.9	57.9	45.5	72.4	60.0	87.0	74.6	102	89.6	116	104	131	119						27.4	15.0		
	S 1-2	35.3	15.8	49.9	30.4	64.4	44.9	79.0	59.5	94.0	74.5	108	88.5	123	103	138	119				42.5	23.0		
	S 2-2			41.9	16.2	56.5	30.8	71.0	45.4	85.6	59.9	100	74.5	115	89.1	130	104	138	112			56.6	31.0	
	S 2-3					50.3	16.6	68.4	31.2	79.4	45.8	94.0	60.3	109.0	74.9	124	90.2	132	98.2			70.8	37.2	
	S 3-3							57.8	17.0	72.3	31.6	86.9	46.2	101.0	60.8	117	76.0	125	84.1			85.0	44.3	
PT050 N	S 1	51.9	34	72.2	54.4	92.5	74.7	113	94.9	133	115	153	136	174	156							47.1	29.2	
	S 2	46.1	24.7	66.3	45.0	86.6	65	107	85.6	127	106	147	126	168	146	188	167					56.5	35.1	
	S 3	40.2	15.2	60.5	35.5	81	55.8	101	76.1	121	96	142	117	162	137	182	157	194	169			65.9	40.9	
	S 4			54.7	26.1	75	46.3	95.2	67	116	87	136	107	156	127	176	148	189	160			75	46.8	
	S 5			48.8	16.7	69	37.0	89.4	57.3	110	78	130	98	150	118	171	138	183	151			84.8	52.6	
	S 6					63.3	27.6	83.5	47.9	104	68	124	88.4	144	109	165	129	177	141			94.1	58.5	
	S 7					57.4	18.1	77.7	38.4	98.0	58.7	118	79.0	139	99	159	120	171	132			104	64.3	
	S 8							71.9	29.0	92.1	49.2	112.4	69.5	133	90	153	110	165	122			113	70.2	
PT100	S 05	94	68.5	130	104	166	140	201	176	237	212	273	247	309	283							74.7	49.1	
	S 06	84.2	53.5	120	89.3	156	125	192	161	227	197	263	232	299	268	335	304					89.6	58.9	
	S 07	74.4	38.6	110	74.4	146	110	182	146	218	182	253	218	289	253	325	289	346	311			105	68.8	
	S 08			100	59.5	136	95.2	172	131	208	167	243	203	279	238	315	274	337	296			119	78.6	
	S 09					126	80.3	162	116	198	152	234	188	269	223	305	259	327	281			134	88.4	
	S 10							152	101	188	137	224	173	260	209	295	244	317	266			149	98.2	
	S 11									178	122	214	158	250	194	286	229	307	251			164	108	
	S 12													240	179	276	214	297	236			179	118	
	S 05	186	131	257	202	328	273	399	344	470	415	541	486	612	557								153	97.8
	S 06	167	100	238	171	309	242	380	313	451	384	522	455	593	526	664	597						184	117
	S 07	147	70	218	141	289	212	360	283	431	354	502	425	573	496	644	567	687	609			214	137	
	S 08			198	110	269	181	340	252	412	323	483	394	554	465	625	536	667	579			245	157	
S 09					250	150	321	221	392	292	463	363	534	434	605	505	648	548			276	176		
S 10							301	191	372	262	443	333	514	404	585	475	628	517			306	196		
S 11									353	231	424	302	495	373	566	444	608	487			337	215		
S 12													475	342	546	413	589	456			368	235		
PT200	S 05	285	191	396	303	508	415	620	526	731	638	843	750	955	862							256	162	
	S 06	252	140	476	252	476	364	587	475	699	587	811	699	922	810	1034	922					307	195	
	S 07	220	89	331	201	443	313	555	424	667	536	778	648	890	759	1002	871	1069	938			358	227	
	S 08			299	150	411	261	522	373	634	485	746	597	858	708	969	820	1036	887			409	260	
	S 09					378	210	490	322	602	434	713	545	825	657	937	769	1004	836			480	292	
	S 10							457	271	569	383	681	494	793	606	904	718	971	785			511	325	
	S 11									537	331	648	443	760	555	872	667	939	734			582	357	
	S 12													728	504	839	616	906	683			613	389	
	S 05	425	301	587	463	750	625	912	787	1074	950	1236	1112	1399	1274							348	224	
	S 06	380	231	542	393	705	555	867	718	1029	880	1192	1042	1354	1205	1516	1367					418	269	
	S 07	335	161	498	323	660	486	822	648	984	810	1147	973	1309	1135	1471	1297	1569	1395			488	314	
	S 08			453	254	615	416	777	578	940	741	1102	903	1264	1065	1426	1227	1524	1325			558	359	
S 09					570	346	732	509	895	671	1057	833	1219	995	1382	1158	1479	1255			627	404		
S 10							688	439	850	601	1012	763	1174	926	1337	1088	1434	1185			697	449		
S 11									805	531	967	694	1130	856	1292	1018	1389	1116			767	493		
S 12													1085	786	1247	949	1344	1046			837	538		
PT300	S 05	687	470	949	732	1211	994	1474	1257	1736	1519	1998	1781	2260	2044							580	363	
	S 06	614	354	876	616	1139	878	1401	1141	1663	1403	1926	1665	2188	1928	2450	2190					696	435	
	S 07	541	238	804	500	1066	762	1328	1025	1591	1287	1853	1549	2115	1812	2378	2074	2535	2231			812	508	
	S 08			731	384	993	646	1256	909	1518	1171	1780	1433	2043	1696	2305	1958	2463	2115			928	581	
	S 09					921	530	1183	793	1446	1055	1708	1317	1970	1580	2233	1842	2390	1999			1044	653	
	S 10							1111	677	1373	939	1635	1201	1898	1464	2160	1726	2317	1883			1160	726	
	S 11									1300	823	1563	1085	1825	1348	2087	1610	2245	1767			1276	798	
	S 12													1753	1232	2015	1494	2172	1652			1392	871	
	S 05	888	623	1226	961	1564	1299	1902	1637	2240	1976	2578	2314	2916	2652								729	465
	S 06	795	477	1133	815	1471	1154	1809	1492	2147	1830	2485	2168	2823	2506	3161	2844						875	558
	S 07	702	331	1040	670	1378	1008	1716	1346	2054	1684	2392	2022	2730	2360	3069	2698	3271	2901			1021	651	
	S 08			947	524	1285	862	1623	1200	1961	1538	2299	1876	2637	2214	2976	2552	3178	2755			1167	744	
S 09					1192	716	1530	1054	1868	1392	2206	1730	2544	2068	2883	2407	3085	2609			1313	837		
S 10							1437	908	1775	1246	2413	1584	2452	1923	2790	2261	2993	2464			1459	930		
S 11									1682	1100	2020	1439	2359	1777	2697	2115	2900	2318		</				

TORQUE OUTPUT (Lb-In)

SPRING RETURN TORQUE

Supply Pressure		40 Psi		50 Psi		60 Psi		70 Psi		80 Psi		90 Psi		100 Psi		110 Psi		116 Psi		Spring stroke			
Model	Spring set	0°	90°	0°	90°	0°	90°	0°	90°	0°	90°	0°	90°	0°	90°	0°	90°	0°	90°	90°	0°		
		Start	End	Start	End	Start	End	Start	End	Start	End	Start	End	Start	End	Start	End	Start	End	Start	End		
PT600	S 05	3312	2406	4610	3704	5908	5003	7207	6301	8505	7599	9803	8898	11102	10196					2787	1882		
	S 06	2935	1849	4234	3147	5532	4445	6830	5744	8129	7042	9427	8340	10725	9639	12024	10937			3345	2258		
	S 07	2559	1291	3857	2589	5156	3888	6454	5186	7752	6485	9051	7783	10349	9081	11648	10380	12427	11159	3902	2634		
	S 08			3481	2032			4779	3330	6078	4629	7376	5927	8674	7225	9973	8524	11271	9822	12050	10601	4460	3011
	S 09					4403	2773			5701	4071	7000	5370	8298	6668	9596	7966	10895	9265	11674	10044	5017	3387
	S 10							5325	3514			6623	4812	7922	6110	9220	7409	10518	8707	11297	9486	5575	3763
	S 11									6247	4255			7545	5553	8844	6851	10142	8150	10921	8929	6132	4140
S 12													8467	6294	9766	7592	10545	8371			6690	4516	
PT650	S 05	5535	4113	7716	6294	9898	8475	12079	10657	14260	12838	16441	15019	18623	17200					4612	3190		
	S 06	4897	3190	7078	5372	9260	7553	11441	9734	13622	11915	15803	14097	17985	16278	20166	18459			5534	3828		
	S 07	4259	2268	6440	4449	8622	6631	10803	8812	12984	10993	15165	13174	17347	15356	19528	17537	20837	18845	6457	4466		
	S 08			5802	3527	7984	5708	10165	7889	12346	10071	14527	12252	16709	14433	18890	16614	20199	17923	7379	5104		
	S 09					7346	4786			9527	6967	11708	9148	13889	11329	16071	13511	18252	15692	19561	17001	8302	5742
	S 10							8889	6045			11070	8226	13251	10407	15433	12588	17614	14770	18923	16078	9224	6380
	S 11									10432	7303			12613	9485	14795	11666	16976	13847	18285	15156	10147	7018
S 12													14157	10743			16338	12925	17647	14233	11069	7656	
PT700	S 05	7836	5576	11002	8742	14168	11907	17333	15073	20499	18239	23665	21405	26831	24571					7088	4828		
	S 06	6870	4158	10036	7324	13202	10490	16368	13656	19534	16822	22700	19987	25865	23153	29031	26319			8505	5793		
	S 07	5905	2741	9071	5906	12236	9072	15402	12238	18568	15404	21734	18570	24900	21736	28066	24902	29965	26801	9923	6759		
	S 08			8105	4489	11271	7655	14437	10821	17603	13986	20769	17152	23934	20318	27100	23484	29000	25384	11340	7724		
	S 09					10305	6237	13471	9403	16637	12569	19803	15735	22969	18901	26135	22067	28034	23966	12758	8690		
	S 10							12506	7986			15672	11151	18837	14317	22003	17483	25169	20649	27069	22549	14176	8655
	S 11									14706	9734			17872	12900	21038	16066	24204	19231	26103	21131	15593	10621
S 12													20072	14648			23238	17814	25138	19713	17011	11586	
PT750	S 05	11059	7868	15441	12250	19823	16632	24205	21014	28587	25395	32969	29777	37351	34159					9660	6469		
	S 06	9765	5936	14147	10318	18529	14700	22911	19081	27293	23463	31675	27845	36057	32227	40439	36610			11592	7763		
	S 07	8471	4004	12853	8386	17235	12767	21617	17149	25999	21531	30381	25913	34763	30295	39146	34678	41774	37306	13524	9056		
	S 08			11560	6454	15942	10835	20323	15217	24705	19599	29087	23981	33469	28363	37852	32746	40480	35374	15456	10350		
	S 09					14648	8903	19030	13285	23412	17667	27794	22049	32176	26431	36558	30814	39187	33442	17388	11644		
	S 10							17736	11353			22118	15735	26500	20117	30882	24499	35264	28882	37893	31510	19320	12938
	S 11									20824	13803			25206	18185	29588	22567	33971	26950	36599	29578	21252	14231
S 12													28294	20635			32677	25018	35305	27646	23184	15525	
PT800	S 05	13855	11037	19353	16536	24852	22034	30350	27533	35849	33031	41347	38530	46846	44028					10957	8140		
	S 06	12227	8846	17725	14344	23224	19843	28722	25341	34221	30840	39719	36338	45218	41837	50717	47335			13149	9767		
	S 07	10599	6654	16097	12153	21596	17651	27094	23150	32593	28648	38091	34147	43590	39645	49089	45144	52388	48443	15340	11895		
	S 08			14469	9961	19968	15460	25466	20958	30965	26457	36464	31955	41962	37454	47461	42953	50760	46252	17531	13023		
	S 09					18340	13268	23839	18767	29337	24265	34836	29764	40334	35263	45833	40761	49132	44060	19723	14651		
	S 10							22211	16576			27709	22074	33208	27573	38706	33071	44205	38570	47504	41869	21914	16279
	S 11									26081	19883			31580	25381	37078	30880	42577	36378	45876	39677	24106	17807
S 12													35450	28688	40949	34187	44248	37486			26297	19535	
PT1000	S 05	25715	18812	35894	28991	46073	39170	56252	49349	66431	59528	76610	69707	86790	79887					21904	15001		
	S 06	22715	14432	32894	24611	43073	34790	53252	44969	63431	55148	73610	65327	83789	75506	93968	85658			26285	18001		
	S 07	19715	10051	29894	20230	40073	30409	50252	40588	60431	50767	70610	60946	80789	71125	90968	81304	97076	87411	30685	21001		
	S 08			26894	15849	37073	26028	47252	36207	57431	46386	67610	56565	77789	66744	87968	76923	94076	83031	35046	24001		
	S 09					34073	21647	44252	31826	54431	42005	64610	52184	74789	62364	84968	72543	91075	78650	39427	27001		
	S 10							41252	27455			51431	37634	61610	47813	71789	57992	81968	68171	88075	74278	43799	30002
	S 11									48431	33253			58610	43432	68789	53611	78968	63790	85075	69897	48179	33002
S 12													55609	39051	65788	49230	75967	59409	82075	65517	52560	36002	
Spring set		The above value are the out-put torque that remain available to operate the valve when the port "2" is pressurized																			Out-put torque available when air supply fails		

DOUBLE ACTING TORQUE

Supply Pressure	40 Psi	50 Psi	60 Psi	70 Psi	80 Psi	90 Psi	100 Psi	110 Psi	116 Psi
PT045 D	58.3	72.9	87.4	102	117	131	146	161	169
PT050 N D	81.1	101	122	142	162	183	203	223	235
PT100 D	143	179	215	251	286	322	358	394	415
PT200 D	284	355	426	497	568	639	710	781	824
PT250 D	447	559	670	782	894	1005	1117	1229	1296
PT300 D	649	811	974	1136	1298	1461	1623	1785	1883
PT350 D	1049	1312	1574	1836	2099	2361	2623	2886	3043
PT400 D	1352	1691	2029	2367	2705	3043	3381	3719	3922
PT450 D	2123	2654	3185	3716	4246	4777	5308	5839	6157
PT500 D	2770	3462	4155	4847	5540	6232	6925	7617	8032
PT550 D	3739	4674	5609	6544	7479	8413	9348	10283	10844
PT600 D	5193	6492	7790	9088	10387	11685	12984	14282	15061
PT650 D	8725	10906	13087	15269	17450	19631	21812	23994	25302
PT700 D	12663	15829	18995	22161	25327	28493	31659	34825	36724
PT750 D	17528	21910	26292	30674	35056	39438	43820	48202	50831
PT800 D	21994	27493	32991	38490	43988	49487	54985	60484	63783
PT1000 D	40716	50895	61074	71253	81432	91611	101790	111969	**

** PT1000 D operated with 8 bar [116 Psi] supply pressure requires SPECIAL construction. Contact AIR TORQUE factory.

ACTUATOR INTERFACE FOR VALVE AUTOMATION - APPLIED STANDARDS

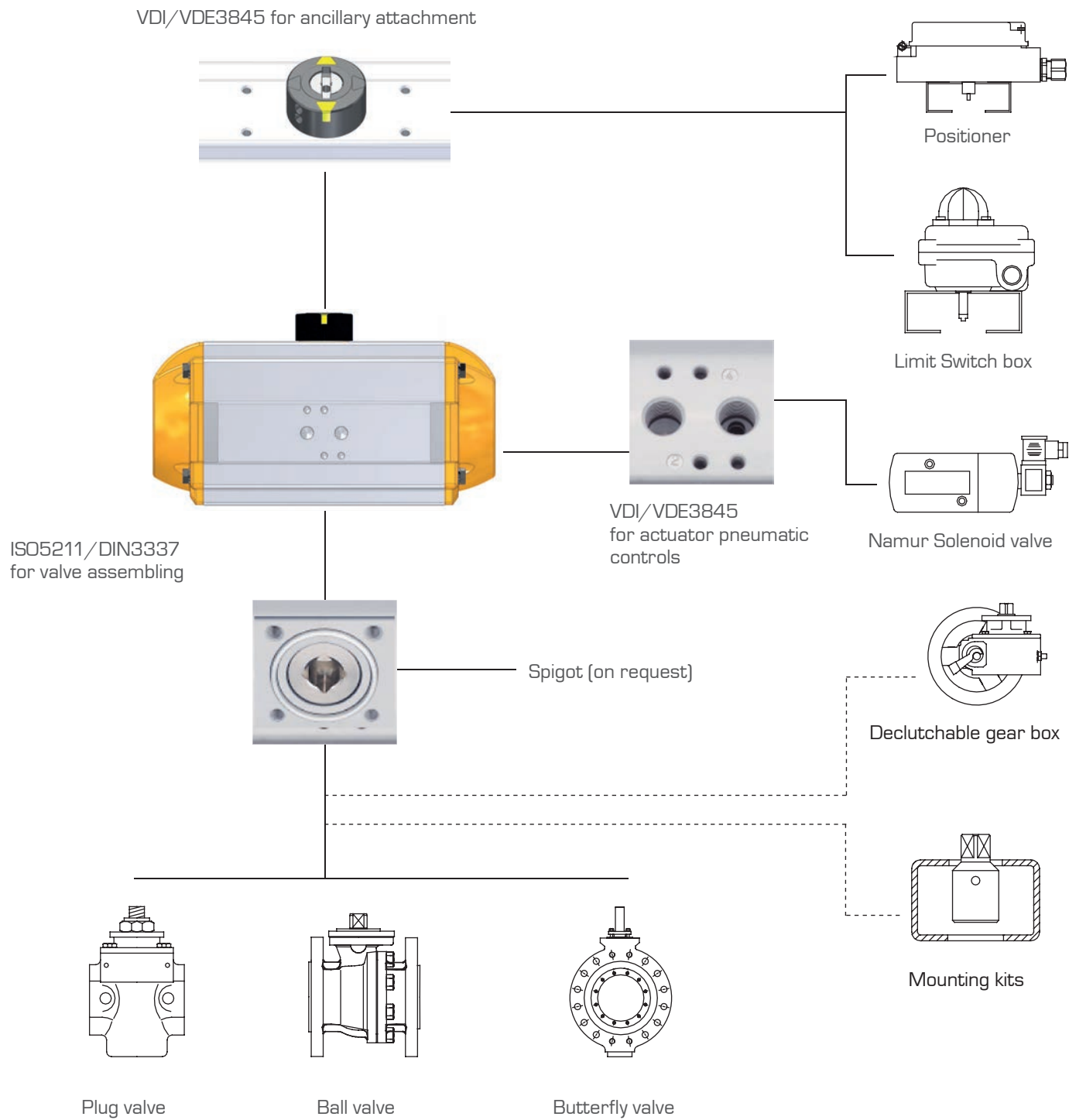

COUPLING AND BRACKETS

Air Torque has a large stock of couplings and brackets.

All the accessories for valve automation available on request.

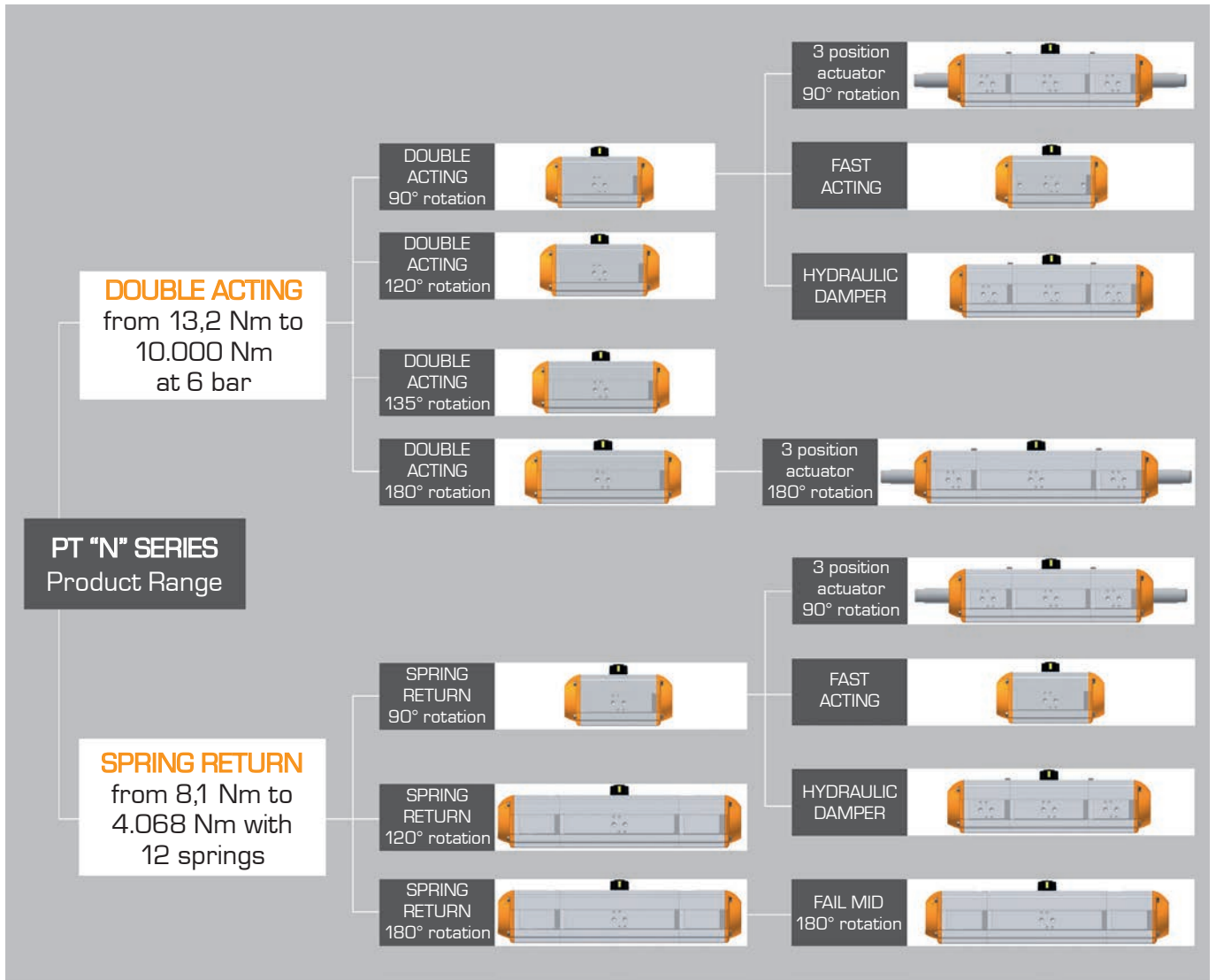

THE PRODUCT RANGE INCLUDES ALSO THE FOLLOWING OPTIONS

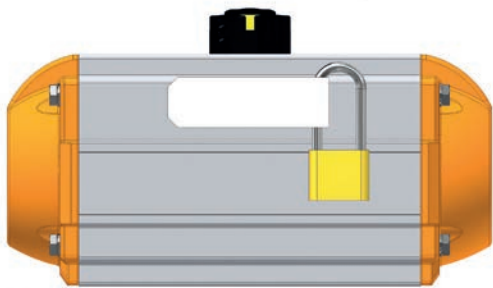

LOOK-OUT CAPABILITY



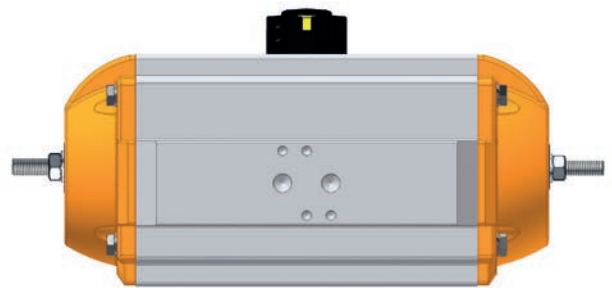

In order to permanently lock the actuator in position, the actuator can be supplied with a special locking device by using a padlock and therefore preventing unwanted operation.



100% TRAVEL STOP LIMITATION

When a stroke of less than 90° is required e.g. 1°, 5°, 10°, 25°, 50°, 70° and the standard adjustment is not suitable, the actuator can be supplied with special bolts in both End-Caps to allow stroke adjustment or limitation from 0° to 90° according to customer requirements.

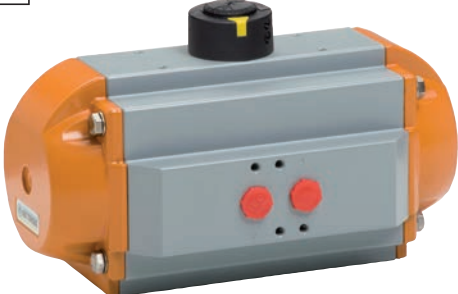
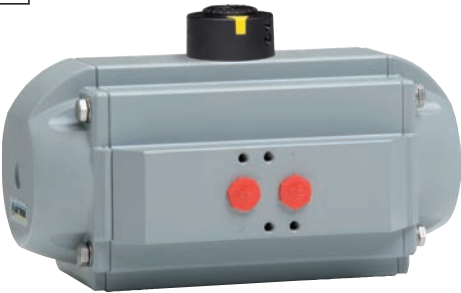
STANDARD PROTECTION LEVELS

PROTECTION LEVEL	PARTS	COATING
A 	Body (PT045 to PT750)	ALODUR anodized
	Body (PT800 and PT1000)	Anodized plus epoxy primer, plus polyurethane coating (RAL9007 - grey)
	End-caps	Anodized plus polyester coating (RAL2011 - orange)
	Carbon steel drive shaft (PT050 N to PT800)	ENP
	Aluminum alloy drive shaft (PT045 and PT1000)	ALODUR anodized
	Carbon steel Spring Clip	ENP
E 	Body	ALODUR anodized plus PTFE coating (light grey)
	End-caps	Anodized plus PTFE coating (light grey)
	Stainless steel drive shaft	ENP
	Stainless steel Spring Clip	N.A.
H 	Body (PT045 and PT750)	ALODUR anodized plus PTFE coating (light grey)
	Body (PT800 and PT1000)	Anodized plus epoxy coating (RAL 7046 light grey)
	End-caps	Anodized plus polyester coating (RAL2011 - orange)
	Carbon steel drive shaft (PT050 N to PT800)	High Thickness ENP
	Aluminum alloy drive shaft (PT045 and PT1000)	ALODUR anodized
	Carbon steel Spring Clip	ENP
L 	Body	ALODUR anodized plus PTFE coating (light grey)
	End-caps	Anodized plus PTFE coating (light grey)
	Aluminium alloy drive shaft	ALODUR anodized
	Sintered Square Reduction (PT050 N to PT200)	Stainless Steel
	Drive Bushing (PT250 to PT600)	ALODUR anodized
	Stainless steel Spring Clip	N.A.
M 	Body	ALODUR anodized plus PTFE coating (light grey)
	End-caps	Anodized plus PTFE coating (light grey)
	Carbon steel drive shaft (PT050 N to PT800)	High Thickness ENP
	Aluminum alloy drive shaft (PT045 and PT1000)	ALODUR anodized
	Stainless steel Spring Clip	N.A.

See technical data-sheet for protection details

HOW TO ORDER Power Technology PT "N" SERIES

Available Options and Ordering codes:

0	00	1	2	3	4	5	6	7	8	9	10							
-	00	PT200	S	12	A	F05+F07	Y	14 D	HT	-	-							
0	Future options																	
00	<p>Blank: for standard actuator R50: 50% travel stop limitation (45° up to 90°) R100: 100% travel stop limitation (0° up to 90°) FA: fast acting FM: fail mid 180° rotation 3P: 3 position (only for spring return) 3PD: 3 position (both for spring return and double acting) HC: hydraulic damper</p>																	
1	<p>Actuator model, series and rotation: 90° Rotation (Standard) = PT045 to PT1000 120° Rotation (only Double Acting) = PT052 to PT752 135° Rotation (only Double Acting) = PT053 to PT753 180° Rotation (Double Acting and Spring Return) = PT058 to PT758</p>																	
2	<p>D = Double Acting S = Spring Return</p>																	
3 (A)	<p>Only for spring return: number of spring, spring set configuration For model PT045: Spring Set configuration S1-1 / S1-2 / S2-2 / S2-3 / S3-3 For model PT050 N: Spring Set configuration S1 / S2 / S3 / S4 / S5 / S6 / S7 / S8 For models PT100 to PT1000 = Number of Spring: > 05 to 12 spring for standard actuators 90° rotation > 10 to 24 spring only for spring return 180° rotation actuators</p>																	
4 (B)	A / H / L / M: Protection Level																	
5	ISO 5211 Flange (See table below)																	
ISO 5211 Flange type available	Model	PT 045	PT 050 N	PT 100	PT 200	PT 250	PT 300	PT 350	PT 400	PT 450	PT 500	PT 550	PT 600	PT 650	PT 700	PT 750	PT 800	PT 1000
	Standard	F04	F04	F05 + F07	F05 + F07	F05 + F07	F07 + F10	F07 + F10	F07 + F10	F10 + F12	F10 + F12	F14	F14	F16 + F25	F16	F16	F16 + F25	F16 + F25 + F30
Options	F03	F03 + F07	F04 + F07								F12	F12	F14		F16 + F25			
6	<p>Blank: no spigot Y: with spigot</p>																	
7 (C)	<p>XXD: single square dimension and diagonal assembling XXL: single square dimension and parallel assembling XXDS: dimension and double square</p> <p>S x d [D]: flat head dimensions W x d: double keys dimensions (for all Square dimensions available see table below)</p>																	
ISO 5211 Square dimensions and type available																		
Model	PT 045	PT 050 N	PT 100	PT 200	PT 250	PT 300	PT 350	PT 400	PT 450	PT 500	PT 550	PT 600	PT 650	PT 700	PT 750	PT 800	PT 1000	
Protection Level "L"	11DS	9SQ	11SQ	14SQ	17SQ	17SQ	22SQ	22SQ	27SQ	27SQ	27SQ	36SQ	46DS	46DS	55DS	55DS	75DS	
Protection Level "A" / "E" / "H" / "M"	11DS	9DS* 11DS	11DS* 14DS	14DS* 17DS	14DS* 17DS	17DS* 22DS	17DS* 22DS	22DS* 27DS*	22DS* 27DS*	27DS	27DS*	27DS* 36DS	36DS* 46DS	36DS* 46DS	46DS* 55DS*	46DS* 55DS	55DS* 75DS	
*only prot. level "E" **only prot. level "A" / "H" / "M"																		
8	<p>Blank: Actuator with standard seals suitable for -40°C (-40°F) to +80°C (+176°F) HT: actuator construction suitable for -15°C (+5°F) to +150°C (+302°F) LLT 2: construction suitable for -60°C (-76°F) to +80°C (+176°F)</p>																	
9 (E)	<p>Blank: standard assembly type ST, clockwise to close (spring to close) and close indication at air failure condition (or with pressurized port 4 for double acting) for in line mounting. LF: counterclockwise to close (spring to open) and open indication at air failure condition (or with pressurized port 4 for double acting) for across line mounting.</p> <p>STR: clockwise to close (spring to close) and close indication at air failure condition (or with pressurized port 4 for double acting) for across line mounting. LFR: counterclockwise to close (spring to open) and open indication at air failure condition (or with pressurized port 4 for double acting) for in line mounting.</p>																	
10	Further requested options																	

All dimensions and materials are referred to updated catalogue and/or technical data sheet.

Notes:

- A) For models PT045 and PT050 N the number indicated is the spring SET configuration and not spring quantity.
- B) For corrosion protection level specification and colour see related T.D.S.
- C) Standard Shaft connection is a female single or double square. For other connections contact AIR TORQUE.
- D) Head flat orientation to be specified, see T.D.S. n° TYAS.
- E) For detailed information see T.D.S. n° TYAS
- F) If not specified the actuators will be supplied with standard Position Indicator Black colour. Optional indicator for sensor or limit switch contact available on request, see related T.D.S.

How to order: examples

0	00	1	2	3	4	5	6	7	8	9	10
-	-	PT200	S	12	A	F05+F07	Y	14 D	HT	-	-

PT200 Series, spring return with 12 springs, protection level A, ISO flange F05-F07, with spigot, 14 mm diagonal single square and high temperature construction, standard position indicator Black colour.

HEAD OFFICE AND WORKS

AIR TORQUE S.P.A.

Head Offices: Via dei Livelli di Sopra, 11

Factory: Via dei Livelli di Sopra, 8

24060 Costa di Mezzate (BG) ITALY

Tel. +39 035 682299

Fax +39 035 687791

info@airtorque.it - www.airtorque.it



AFFILIATE DISTRIBUTORS

Air Torque GmbH

Im Katzentach 16-18

76275 Ettlingen

Germany

Phone: +49 7243 59340

Fax: +49 7243 593434

Email: info@airtorque.de

Air Torque (UK) Ltd

Unit 6 Interlink Way South

Bardon Hill Coalville

Leicestershire LE67 1PH

United of Kingdom

Phone: +44 1530 832832

Fax +44 1530 838986

Email: sales@airtorque.uk.com

Air Torque France

(division de STF)

7, Parc d'activités de la

Verdière 13880 VELAUX

France

Phone: +33 442878400

Fax: +33 442878404

Email: infos@star-line.fr

AIR TORQUE WORLDWIDE DISTRIBUTION NETWORK

EUROPE

Austria

Belgium

Czech Republic

Denmark

Finland

France

Germany

Greece

Italy

Netherland

Norway

Poland

Portugal

Russia

Slovenia

Spain

Sweden

Switzerland

UK

AMERICA

Argentina

Brazil

Canada

Chile

Colombia

Mexico

USA

AFRICA

Egypt

Morocco

South Africa

OCEANIA

Australia

New Zeland

Papua & New Guinea

ASIA

China

India

Indonesia

Israel

Japan

Kazakhstan

Malaysia

Pakistan

Singapore

South Korea

Taiwan

Thailand

Turkey

UAE & Qatar

Vietnam

Yemen

