

**GEMÜ**



**Solutions for microelectronics,  
semiconductors and battery production**



# Table of contents

Major areas of application . . . . .	6	GEMÜ system solutions examples . . . . .	26 - 27
Growth applications . . . . .	7	GEMÜ iComLine . . . . .	28 - 35
Semiconductor production . . . . .	8	GEMÜ CleanStar . . . . .	36 - 39
Areas of application . . . . .	9	GEMÜ PurePlus . . . . .	40 - 41
Chemical supply application examples . . . . .	10 - 11	GEMÜ 600 HP/677 HPW . . . . .	42 - 43
Ultra pure water treatment application examples . . . . .	12 - 13	GEMÜ HydraLine . . . . .	44 - 45
Slurry supply application examples . . . . .	14 - 15	GEMÜ SonicLine . . . . .	46 - 47
Solvent supply application examples . . . . .	16 - 17	GEMÜ FlareStar/TubeStar . . . . .	48 - 49
Wet process equipment application examples . . . . .	18 - 19	GEMÜ Check Valve CV . . . . .	50 - 51
Waste water treatment application examples . . . . .	20 - 21	Stainless steel components . . . . .	52 - 53
Lithium-ion battery cell production application examples . . . . .	22 - 23	Overview of GEMÜ products . . . . .	54 - 55
Components and system solutions . . . . .	24-25	It's all about the right service . . . . .	56
		GEMÜ Green Engineering . . . . .	57
		Permanently controlled quality . . . . .	58 - 59
		Product overview . . . . .	60 - 62
		Worldwide presence . . . . .	63



Gert Müller, Managing Partner

## GEMÜ Group

Founded in  
**1964**

Over  
**1900**  
employees worldwide

**6**  
manufacturing sites

**27**  
sales companies

## GEMÜ structure



The GEMÜ Group is a leading manufacturer of valves, measurement and control systems employing over 1900 members of staff worldwide. With six manufacturing sites and 27 subsidiaries, as well as a large network of commercial partners, GEMÜ is now active in over 50 countries on all continents.

### Reorganized – for even greater proximity to our customers

With our wide product range, we offer solutions for the most varied customer groups. We work close to the customer in our strategic business units:

- Pharma, Food & Biotech
- Industry
- Semiconductor
- Service
- Medical

The widely positioned modular system and the adapted automation components enable us to combine individualized standard products and customized solutions to create a large number of different configurations and variants.



## Valves, measurement and control systems for the semiconductor, microelectronics, solar energy and optoelectronics industries

GEMÜ has excellent references for using valves in areas of application that have high purity requirements. Our products are used specifically for process equipment, ultra-pure chemical supply systems, ultra-pure water treatment plants and ultra-pure water distribution installations. Areas of application include the fields of optics, medicine, photovoltaics, electronics and microelectronics, semiconductor production, the pharmaceutical industry, biotechnology and gene technology as well as precision mechanics and micromechanics.

### Coordinated technologies for efficient processes

GEMÜ products are the result of our close collaboration with users, designers and equipment manufacturers. Products and components for ultra pure applications are manufactured by GEMÜ in cleanroom conditions. GEMÜ recognized this necessity at an early stage and invested in a suitably adapted production plant and facilities. As of September 2012, all high-purity products are manufactured at a modern cleanroom facility in Emmen in the canton of Lucerne in Switzerland. The valve components are injection-moulded, cleaned, assembled, tested and packed there using the very latest technology and processes.

# Major areas of application

## Our range of products and services

We cannot imagine our modern world without semiconductor technology. Computers, telephones and flat screens only represent a fraction of the products which we use without thinking about the technology involved at all. These products and their components (microchips) are manufactured under highly pure conditions. Numerous plant designers and end users select GEMÜ products when equipping their devices and production plants for media control and regulation.

In future too, semiconductors will play an important role. After all, they are a central element in the development of autonomous driving, many new smartphone functionalities and so-called wearables like smartwatches, fitness trackers, etc., all of which are equipped with sensors or communication chips. But the subjects of the Internet of Things (IoT) and cloud computing are continuing to drive the demand for high-performance chips.

The purity of the process media used in many high-tech areas is increasingly decisive for the quality and yield of the products.

### The range of applications includes:

- Semiconductor industry
- Microchip, flat panel, LED production
- Photovoltaic industry
- Chemical industry
- Pharma/food
- Analysis, medical systems
- Renewable sources

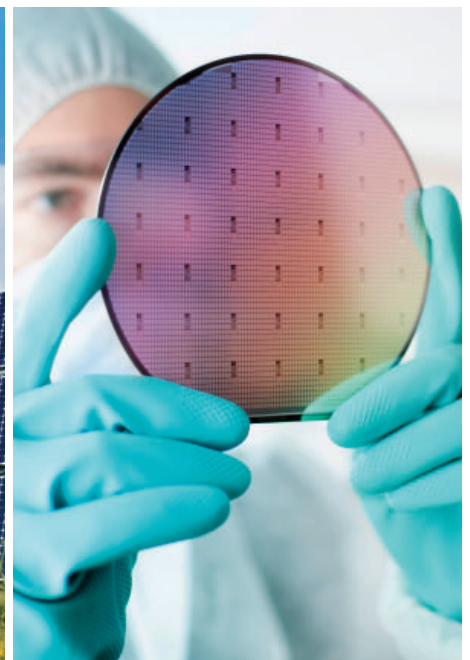

# Growth applications

Welcome to the future – sustainable and efficient

## LED and OLED technology

Energy-efficient lighting, traffic signal systems, giant screens such as those found in stadiums, advertising boards, portable games consoles, modern TV screens or even the simple LED flash bulb on your mobile phone camera: These tiny light emitting diodes are found in many places. This development is set to continue because of the long service life and low energy demand of LEDs. So with falling production costs, we should not be surprised to come across even more of these diodes in future. GEMÜ supports LED manufacturers and their plant suppliers with its broad range of products for highly complex manufacturing processes.

## Biotechnology and medical industry

Classic biotechnology and medical technology applications will continue to demand a large proportion of minimal contamination production processes in the future. GEMÜ valves are at the peak of international competition for functionality and quality in this regard. That makes it possible to develop manufacturing methods for chemical compounds, e.g. as active substances in pharmaceuticals or as basic chemicals for the chemical industry, diagnostic methods, biosensors, new plant strains and many other things.

## Battery technology

Lithium-ion rechargeable batteries supply the power for portable devices with a high energy demand and for which conventional nickel-cadmium or nickel-metal hydride batteries would be too heavy or too large, devices such as mobile phones, digital cameras, camcorders, notebook computers, hand-held consoles or torches. They also serve as energy stores for electric bicycles, electric cars and hybrid vehicles in the field of electric mobility. GEMÜ supports battery manufacturers with their sensitive manufacturing processes by helping them create "contamination-free" production environments.

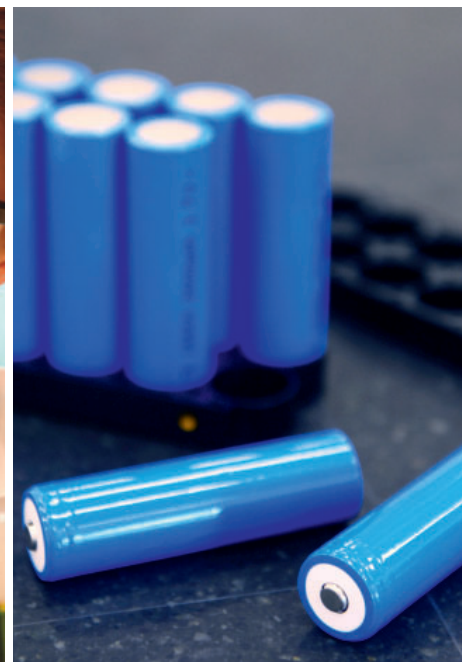



## Semiconductor production

### The right solution for every requirement

GEMÜ's many years of experience in the different areas of semiconductor production and its core skills in handling critical media enable it to offer a product range tailored to the specific requirements of the semiconductor industry. In addition, with customized solutions and an extensive system offering, innovative solutions to specific problems can be developed together with the customer.

As semiconductor products become more complex, so too do the process complexity and the requirements for the process plants, which must be taken into consideration during conceptual design, become more complex. Different media are required for each of the many processing steps that a silicon wafer undergoes:

From corrosive chemicals to chemically reactive ultra-pure water and on to corrosive slurry and easily flammable solvents, which, by nature, all set specific requirements for the process systems.

Depending on whether these media are required in core processes or in auxiliary processes, there may be additional requirements. Whilst plants in the wet processing area must be particle-free, precise and compact, it is cost efficiency, constant supply and reliability that are fundamentally important in the supply area.



# Areas of application

From supply level in a semiconductor factory to the mixing and distribution level and on to use in the cleanroom process equipment. GEMÜ components and system solutions for control and regulation of process media are used in different areas of a semiconductor factory.

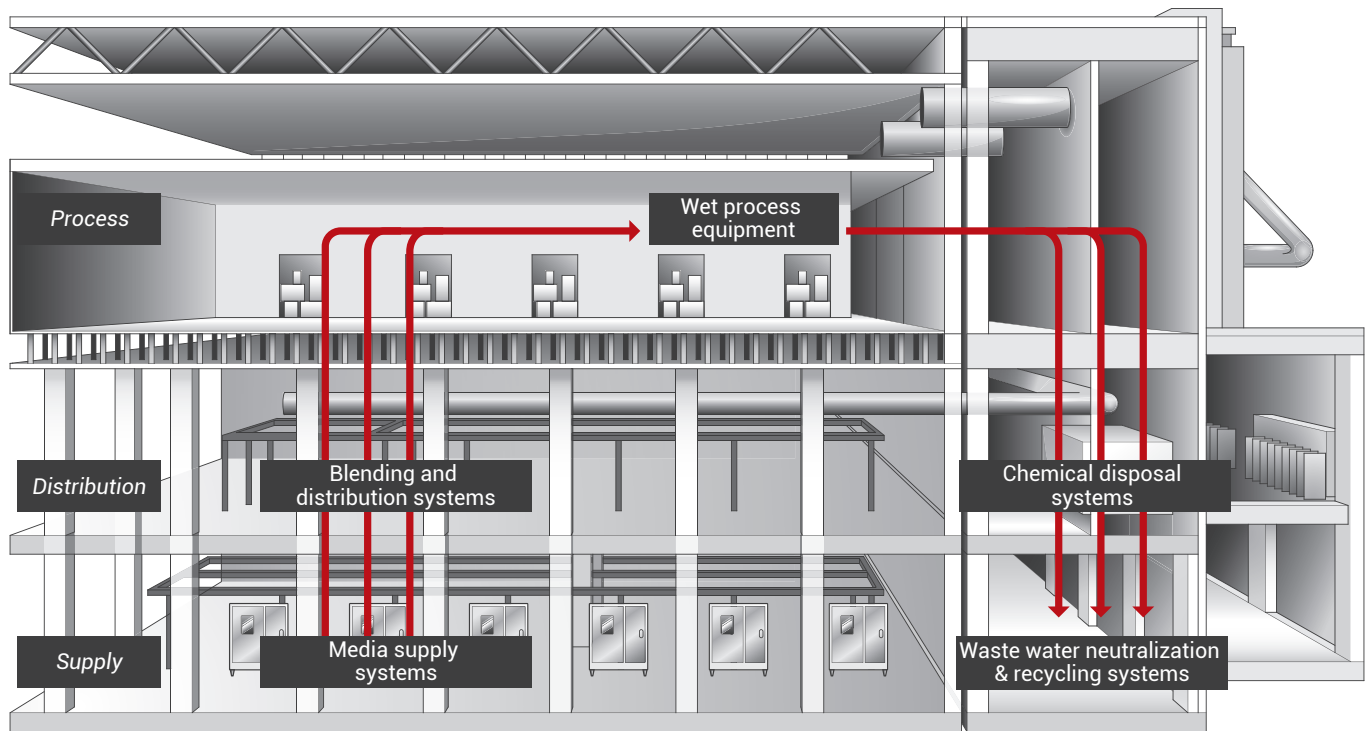

Range of applications for valves, measurement and control systems from GEMÜ in a semiconductor factory.

Area of application	Application examples
Media supply systems	Ultra-pure water treatment and supply installation, chemical, solvent and slurry supply modules
Blending and distribution systems	Valve manifold boxes (VMB), CMP slurry mixing plants, chemicals mixing and distribution modules
Process equipment	<p>CMP plants, wafer coating system, wet etching and cleaning installations, parts cleaning installations, FOUP cleaner, retrofit solutions and upgrades for existing systems</p> <p>Raw wafers      Lithography      Etching processes      CMP      Structured wafers</p> <p>Slicing and polishing    Cleaning    Coating    Exposing and developing    Wet etching    Cleaning    Polishing    Cutting to size and packaging</p> <p>Process repeated up to 40 times</p> <p>Front end process      Back end process</p> <p>Front end process: Wafer processing with GEMÜ components and system solutions</p>
Waste water neutralization, media disposal & recycling	Waste water neutralization plants, CMP slurry recycling plants



## Chemical supply

### High Performance - High Flow valves for your chemical supply

GEMÜ offers products and system solutions that, due to their high resistance and uncompromising purity, are particularly well suited to use in the chemical supply.

The purity of the process media used in many areas of high-tech production is increasingly decisive for the quality and quantity of the products. The corrosive ultra-high-purity chemicals required in many cleaning and etching processes also set high requirements in terms of the resistance of the systems and their components.

Numerous plant designers and end users select GEMÜ products when equipping their devices and production plants for reliable and high-performance media control and regulation.

The areas of application range from use in processing devices, in particular for cleaning, coating, etching and filling, to use in chemical mixing and supply systems. A further area of application is in the production and filling of fine chemicals as well as in the production and filling of technical chemicals for water and waste water treatment.

# Application examples



Chemical supply module for chip production

## Chemical supply for ultra pure areas of application

The GEMÜ product range comprises products of high resistance and uncompromising purity.

These are used for:

- Chemical supply systems for wet process equipment
- Ultra-pure chemical supply for LED and microchip manufacture
- Chemical filling installations

PFA components of the following GEMÜ product groups are typically used: CleanStar, iComLine, SonicLine, HydraLine, FlareStar, TubeStar



Chemical filling installation

## Chemical supply for pure areas of application

GEMÜ has specialized products for applications which need to be clean but not ultra-pure.

These products are used for the following applications:

- Manufacture of solar wafers and flat panels
- Secondary processes in Pharma, Food and Biotech sectors
- Processes in analytical and medical equipment sectors

PFA and PVDF as well as PP components of the following GEMÜ product groups are typically used: CleanStar SmartLine, SonicLine, PurePlus



Supply module for technical chemicals

## Technical chemical supply

In technical chemical supply applications the resistance to media is given priority.

GEMÜ offers products for the following applications:

- Applications and processes in circuit boards manufacture and electroplating
- Chemical supply systems for waste water treatment
- Exact dosing of chemicals

PFA, PVDF, PVC, PP components of the following GEMÜ product groups are typically used: PurePlus, iComLine, CleanStar SmartLine





## Ultra pure water treatment

Tried and tested –  
Valves, measurement  
and control systems  
from a single source

With its wide range of products in valves, measurement and control systems, GEMÜ offers the right solutions for your activity in ultra-pure water treatment and supply.

In process plants, ultra-pure water and pure water play an increasing role in the quality of the final products in high-tech production. Treated water with different levels of purity and quantities is required in the following applications:

- Microchip manufacture
- LED production
- Processes in medical technology
- Pharma, Food & Biotech
- Cooling water for processing devices

GEMÜ diaphragm valves have proven their value in particular in the field of ultra-pure water treatment and distribution systems. In the treatment and distribution of highly tempered ultra-pure water, they enable safe operation not only at high temperatures but also under high pressures.

# Application examples



Basic supply of semiconductor factories, ultra pure water treatment

## UHP (Ultra High Purity) water treatment

GEMÜ offers an extensive range of products which ensure uncompromising purity.

UHP water treatment plants are used in the following sectors:

- Ultra pure silicon wafer manufacture
- Microchip manufacture
- Production of LEDs

Typically used products: PVDF-HP components from the PurePlus product range



DI water treatment

## DI water treatment for pure areas of application

GEMÜ has specialized products for the following applications where deionised (DI) water is required.

DI water treatment plants are used for the following sectors:

- Manufacture of solar wafers/cells
- Flat panel manufacture
- Analysis, Medical Systems, Pharma, Food and Biotech

Typically used products: PVDF and PP components of the following product ranges: CleanStar SmartLine and PurePlus



Water treatment  
(company Treitel Chemical Engineering Ltd)

## Process water treatment and supply

In addition to components for critical fluid handling, GEMÜ offers an extensive range of valves, measurement and control systems for many standard applications in water treatment:

- Water conditioning and temperature control
- Water filtration
- Cooling water for demanding processing devices

Typically used products: PVDF, PP and PVC components as well as multi-port valve block systems





## Slurry supply

### Resistant – Your solution for abrasive slurry

GEMÜ can offer valve and media-friendly solutions for your slurry supply, thanks to the special design of the seat contour.

Safe handling of abrasive media demands particular attention right from the planning and design phase. Typically, a variety of abrasive media is required for widely differing process stages in semiconductor production.

For cutting silicon into ingots or slicing the wafers, a fluid known as "cutting slurry", a suspension that is usually very coarse-grained, is required. Polishing slurry, which is used for the CMP process (chemical-mechanical planarization), on the other hand, tends to be fine. Polishing is an important stage in the manufacture of mirror-finish wafers, to which photoresist can then be applied for precision structuring.

GEMÜ products are used successfully in the production and supply of slurry as well as in the treatment and recycling of slurry.

# Application examples

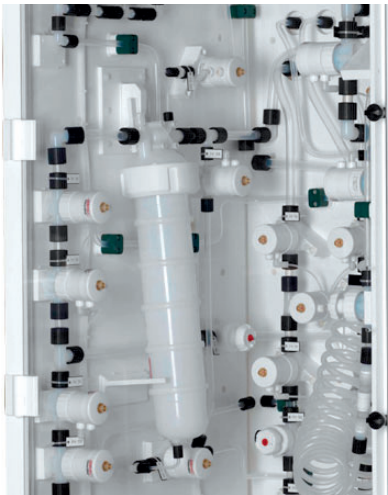

CMP slurry

## Slurry systems in microelectronics

For CMP slurry applications, GEMÜ offers components that meet the strictest demands. Due to their flow-optimized geometry, the slurry containing the abrasive particles is carefully handled.

Common application areas in microelectronics are:

- Mixing systems for CMP slurry
- Supply systems and suppliers for the slurry
- Processing devices

Typically used products: PFA components from the CleanStar series, measurement systems from the HydraLine and SonicLine series as well as fittings from the FlareStar series



Cutting slurry

## Cutting slurry supply systems

As well as the plastic valves and flowmeters, GEMÜ also offers high-quality metal fittings for cutting slurry. The valve geometry also enables low-impact and safe media delivery.

Cutting slurry is used in the following applications:

- Cutting silicon wafers from ingots
- Slurry manufacture
- Supply of the slurry from mixing and storage tanks

Typically used products: Stainless steel components



Slurry supply (company Puerstinger)

## Recycling polishing agents and slurry

Recycling of expensive slurries is also becoming more common for ecological reasons.

GEMÜ can offer components in the following application areas:

- Reconditioning and recovery of slurry in photovoltaic device production
- Slurry for CMP processes
- Supply systems

Typically used products: Plastic and metal diaphragm valves





## Solvent supply

### Safe – The safe solution for solvents

GEMÜ's minimized deadleg stainless steel valves and multi-port valve block systems in stainless steel are extremely compliant with the requirements for resistance and purity, and ensure explosion protection according to ATEX.

In the semiconductor industry, a range of organic solvents such as isopropanol, acetone and N-methylpyrrolidone (NMP) are generally used to dissolve substances and for cleaning purposes. For example, in the lithography process, photoresist is removed with special solvents. Solvent supply modules are found in particular in microchip and LED production as well as in the coatings and paint industry.

The critical and corrosive solvents set stringent requirements in terms of the chemical resistance of the system components. In addition, freedom from particles and thus a high level of purity of the components is required for solvents too. Explosion protection must be ensured in the case of flammable solvents.



# Application examples

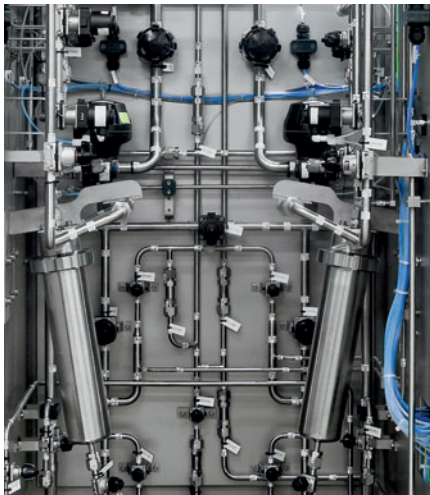

Stainless steel components with plastic actuators

## Stainless steel components for ultra-pure solvents

Normally, stainless steel bodies are used in high-purity solvent applications. Due to their chemical resistance, plastic manual operators and automatic actuators are also used.

Standard areas of application are:

- Blending and solvent processes
- High-purity solvent supply
- Resistance to other etching processes

Due to the optimized seal contour of the stainless steel body, reliable and positive external sealing is ensured.

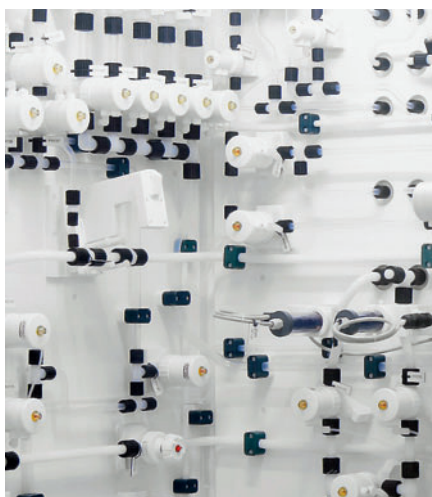

PFA components

## PFA solutions for ultra pure solvents

Due to the stringent requirements for resistance, and for cost reasons, PFA components are used.

Ultra pure solvents in the semiconductor industry are used in the following applications:

- Microchip manufacture
- Blending and solvent processes
- High-purity solvent supply systems

GEMÜ offers a wide range of PFA products, providing high Kv values and cost-effective solutions.



GEMÜ M600 in stainless steel

## Compact multi-port valve blocks in high-purity solvent supply

Due to the flexible, space-saving construction and the associated cost savings, compact multi-port valve blocks from the company GEMÜ are an exciting alternative to single valves.

GEMÜ offers components for the following areas of application:

- Microchip manufacture
- Blending and solvent processes
- High-purity solvent supply systems

Typically used products: Stainless steel and plastic multi-port valve blocks M600 and iComline





## Wet process equipment

### Compact – Modular system for customized valve block systems

With its many years of experience in the customized design of components and subsystems, GEMÜ can provide you with expert advice on your wet process equipment and a product range that precisely meets your needs.

An important part of the core processes of any semiconductor production system is carried out in what are known as wet process plants. The demands of the plants and their components differ according to the process concerned.

Whilst in wet chemical processing of photovoltaic cells, smaller quantities of corrosive acid are used and purity plays a subordinate role, the production of modern microchips involves the use of numerous corrosive media which also demand very high standards in terms of particulate removal and chemical purity.

As all media wetted parts for our high-purity valves are made of PTFE or PFA and produced in a cleanroom, they possess the necessary chemical resistance and high-purity properties.

# Application examples



Chemical supply for wet processes

## Wet processes in microchip manufacture

For the highest purity and resistance demands, GEMÜ offers a comprehensive range of valves, measurement and control systems.

Processes in wet process applications that require high-purity components include:

- Wafer cleaning
- Etching in the manufacture of micro-electronic circuits
- Electroplating

Typically used products: PFA diaphragm valves, block valves and sensor systems such as HydraLine pressure measurement system and SonicLine flowmeter



Process plant

## Etching, cleaning and coating processes

Wet processes, such as those used in the production of photovoltaic components, demand high levels of resistance. The purity of the media is a secondary consideration.

GEMÜ offers a comprehensive product range for the following applications:

- Polysilicon etching in ultra pure silicon manufacture
- Ingot and wafer production
- Glass substrate cleaning and component cleaning

Typically used products: PFA, PVDF as well as PP components



Media area of an etching and cleaning installation

## Industrial wet processes

For industrial wet process applications that demand good valve resistance, GEMÜ offers a wide range of products.

GEMÜ is the company to call for the following wet industrial processes:

- Galvanizing procedures
- Chemical production and filling plants
- Metal separation plants

Typically used products: PP and PVDF components



## Waste water treatment

### Robust – For sustainable waste water treatment processes

For the individual treatment steps in waste water treatment, GEMÜ offers a coordinated product portfolio of robust and chemically resistant plant components.

Industrial waste water treatment is important in a semiconductor factory. The waste water from the different processes sets strict demands for the components used in relation to physical and chemical resistance.

The chemicals used to produce the wafers must be neutralized before disposal, as they would otherwise be harmful to health.

The usual chemical and physical treatment processes are:

- Neutralization of chemically contaminated waste water
- Precipitation of solutes
- Ultra-filtration

# Application examples



Plant with PP components

## Chemical technology in the semiconductor industry

Due to the numerous corrosive chemicals used in the production processes, a large proportion of the waste water from the semiconductor industry has to be chemically neutralized.

Chemical technology for waste water treatment is used in the following areas, for example:

- Ultra pure silicon wafer manufacture
- Microchip manufacture
- Production of LEDs

Typically used products: PFA, PVDF as well as PP components, which are appropriately resistant

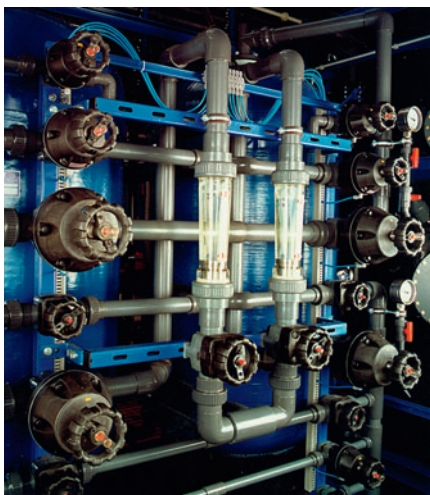

Waste water plant with PVC/PE components

## Precipitation in waste water treatment

Precipitation is a typical waste water treatment process in which a solute is precipitated out of a solution by means of additives of suitable substances (precipitants).

Chemicals are added in the following precipitation processes:

- Softening
- Phosphate elimination
- Slurry-contaminated process waste water

For precise metering of the precipitant chemicals, flowmeters such as the SonicLine products are used.



Waste water plant with PVC/PE components

## Waste water treatment in industry in general

Waste water has to be treated in a large number of industrial production and manufacturing processes.

As a solution provider, GEMÜ offers a wide range of products for the most varied waste water applications:

- Treatment of leachate from rubbish dumps
- Municipal waste water treatment
- Industrial waste water treatment

Typically used products: Butterfly valves, diaphragm valves, globe and control valves, ball valves as well as measurement and control systems





## Lithium-ion battery cell production

### Solutions for

- Slurry mixing
- Coating
- Electrolyte filling

GEMÜ components and system solutions guarantee the purity of the chemicals, prevent contamination and enable the monitoring and automated control of process parameters.

In the manufacture of lithium-ion battery cells, a wide range of different chemicals are mixed, coated and filled in different production processes. The handling of chemicals, in particular the production of electrolytes and the process of filling the battery cell with electrolytes, are among the core processes in battery production and have a crucial influence on the quality and service life of a battery.

Contamination-free battery cell production ensures the maximum manufacturing yield. In particular for  $\text{LiPF}_6$  electrolytes, contamination with water or air results in the production of hydrofluoric acid (HF), which damages the battery cell and chemically attacks the components of the production plant. Chemical resistance, purity and tightness in the plant system are therefore extremely important.

# Application examples



Production research at the ZSW: 60-litre mixing system for electrode pastes. Image: ZSW

## Chemical supply in slurry mixing processes

A typical process in the manufacture of battery cells is the mixing of the coating suspension (slurry) for the electrode films.

The following aspects are particularly important:

- Optimal mixing ratio in the production of slurry
- Valve control in the chemical supply and chemical dosing
- High degree of standardization

Different industrial components are used.



Production of electrode strips under near series conditions at the Centre for Solar Energy and Hydrogen Research (ZSW). Image: ZSW

## Coating of the electrode films

The coating of anode and cathode films is a central manufacturing process, which significantly influences the performance capability of the rechargeable batteries.

The following factors are particularly important:

- Optimal viscosity of the slurries and precision of layer thickness
- Good cleanability of the component (cavity filled)
- Controllability of the process parameters

Typically used products: GEMÜ 650 or C60 in conjunction with a positioner – e.g. GEMÜ 1435 ePos



Electrolyte filling of the battery cells with GEMÜ multi-port valve block in stainless steel

## Electrolyte filling of the battery cells

Filling of the battery cells with electrolyte liquid is a highly complex process, which sets strict requirements for the valve technology

The following factors are particularly important:

- Pressure and vacuum-resistant components
- No contact between the electrolyte and  $H_2O$  or  $O_2$ , as otherwise hydrofluoric acid would be released
- Precise filling with integrated control systems

Typically used products: Block solutions in stainless steel with high-grade surface finish or plastic (iComLine)



# Components and system solutions

Components and system solutions for high-purity, semiconductors and critical fluid management





# System solutions

At the end of the brochure, you will find a table containing an overview of all products and their designs

GEMÜ iComLine

GEMÜ CleanStar

GEMÜ PurePlus

GEMÜ 600 HP/677 HPW

GEMÜ HydraLine

GEMÜ SonicLine

GEMÜ FlareStar

GEMÜ TubeStar

GEMÜ Check Valve CV

GEMÜ stainless steel components

GEMÜ industry components

GEMÜ instrumentation and accessories



## GEMÜ system solutions

### Compliance with customized requirements

As your partner, GEMÜ works together with you to develop customized system solutions. Your specific requirements are competently and reliably translated into a technical specification and implemented in an initial prototype.

GEMÜ is pleased to accept each of your specific tasks and implements these precisely in systems at the highest level of purity. Throughout the entire process, from design & engineering to the finished product as well as the after sales service, a GEMÜ contact will always be on hand to answer any questions.

We provide solutions that satisfy requirements for the following tasks:

- Measurement and control of flow, pressure and temperature through valve positioning or plant control
- Measurement of consumption values
- Monitoring of process parameters and consumption values
- Subassemblies such as pre-fabricated manifolds and back pressure control units
- Integration of sensor system and subassemblies in multi-port valve blocks

Whatever you imagine and we develop together with you can become a reality at GEMÜ.

# Examples of system solutions



Back pressure control system in a box

## System for pressure measurement and back pressure control

The construction of a solution for back pressure control comprising a wide range of GEMÜ products is shown in the adjacent image:

By means of the GEMÜ 4232 travel sensor, the GEMÜ 1436 cPos process controller controls the position of the GEMÜ C60 CleanStar diaphragm valve, which serves as the actuator. In order to correctly set the position of the valve, the GEMÜ 1436 cPos process controller compares the specified set value with the actual value. For detection of the actual value, the GEMÜ C32 HydraDry pressure measurement device with external display is used.



Flow control system

## Flow measurement and control in a system

As with back pressure control systems, flow control systems can also be constructed using GEMÜ products. In this case, the GEMÜ C38 SonicLine ultrasonic flowmeter is used to detect the actual value. The GEMÜ 1436 cPos process controller sets the GEMÜ C60 CleanStar diaphragm valve to the required flow rate with the aid of the GEMÜ 4232 travel sensor in order to obtain the desired set value.

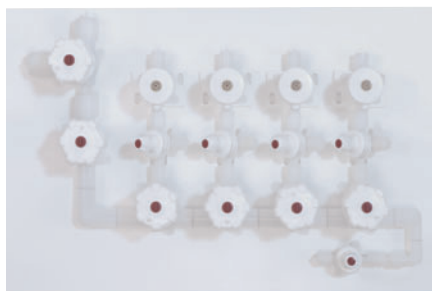

Manifold

## VMBs – manifolds for your valve manifold boxes

Manifolds are pre-assembled manifolds made of valves and fittings. They are put together according to customer-specific requirements. They generally consist of a main pipe and an optional number of branch pipes (sticks). The valves and fittings are joined by welded and/or flared connections.



Multi-port valve block with integrated sensor unit and integrated temperature sensor

## Integration of sensors and functional subassemblies

The function of multi-port valve blocks can be easily extended through the integration of sensor systems and additional functional subassemblies. In this way, different measurement and control components can be used depending on requirements: Pressure and temperature sensors, Ph value measurement sensors, check valves as well as electrical position indicators and process controllers. In addition, individual extensions to housing walls and filter housings are possible.

# GEMÜ iComLine

## Multi-port valve block systems

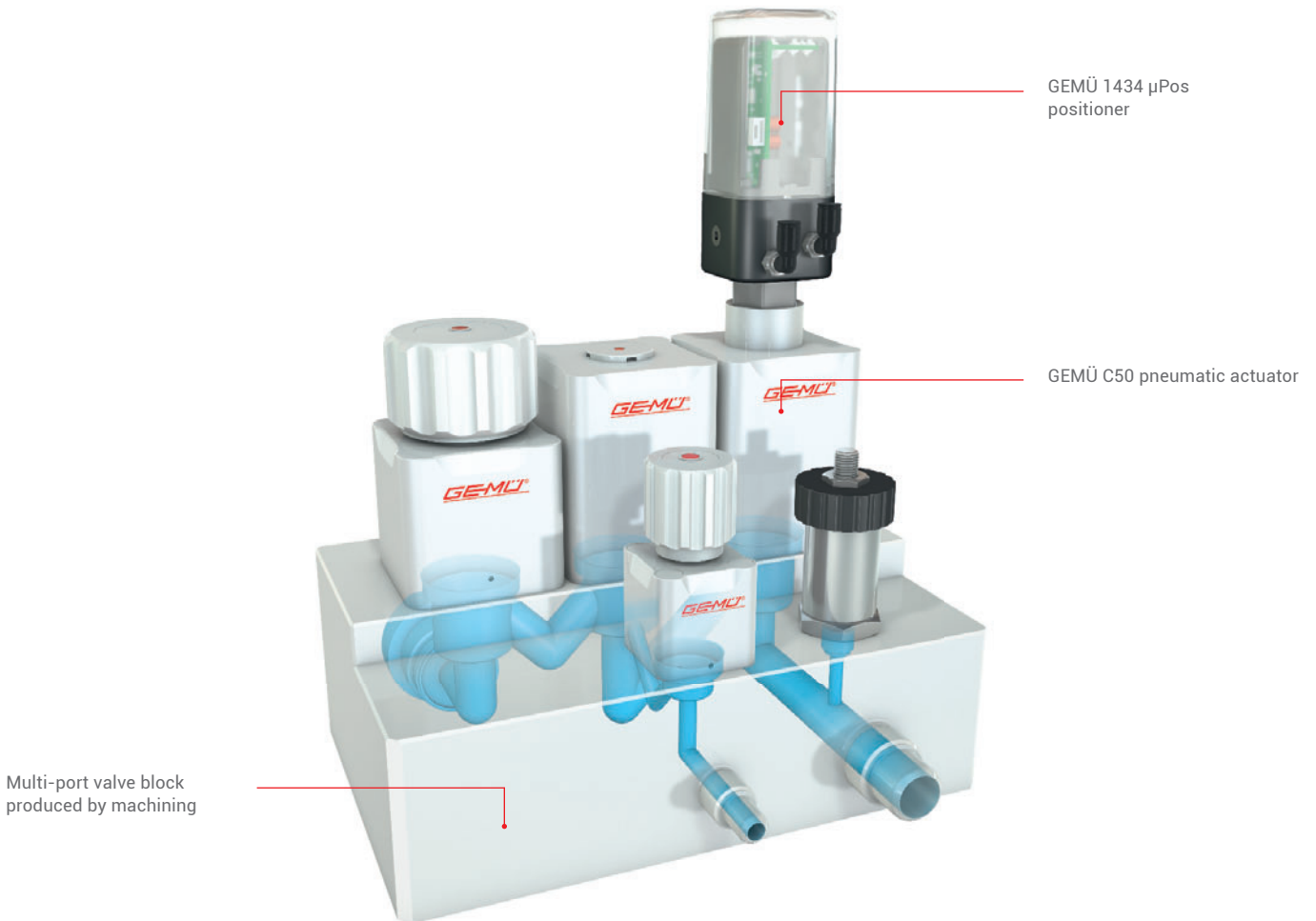

Multi-port valve block produced by machining

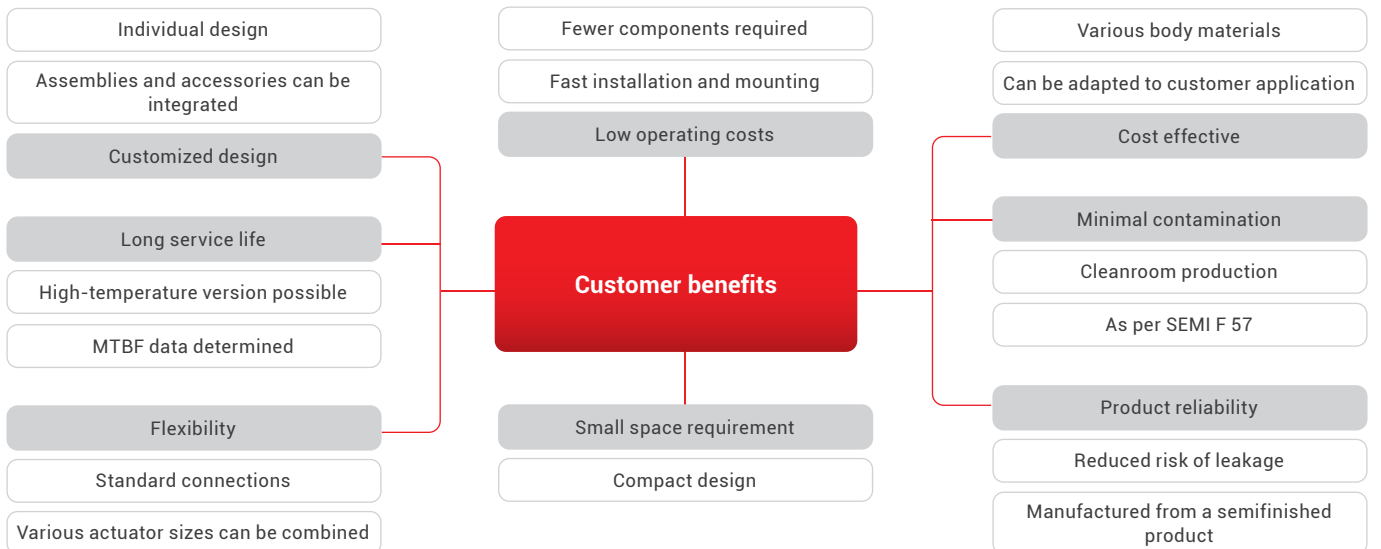

## Product highlights



### Features and advantages

- Individual, customized and very flexible design
- Faster installation and mounting
- Reduced storage costs
- Combination of various connection and actuator sizes
- Sensors can be integrated (e.g. pressure sensor, temperature sensor)
- Various body materials: PTFE (TFM), PVDF, PP, PVC
- Connections: Flare, Pillar, butt weld spigot, female thread, union ends, PrimeLock, clamp, customized process connections



### Implementation of compact manifolds

The adjacent photo shows a compact multi-port valve block providing considerable space savings compared to conventional designs. Other benefits of the multi-port valve block:

- Reduced number of connection points
- Reduced risk of leakage
- Shorter installation time

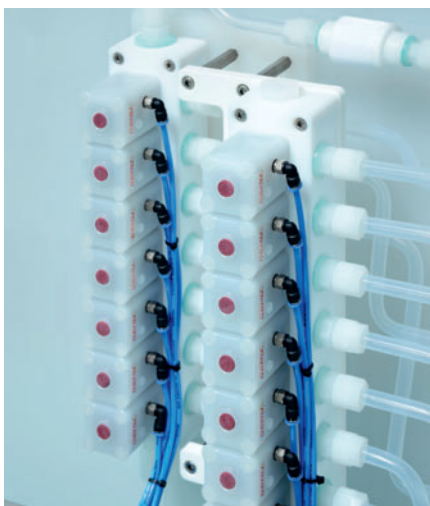

### Areas of application

Suitable for many areas of application due to choice of appropriate valve body/block materials:

- PTFE/PVDF HP valve block for ultra-pure applications in the semiconductor industry
- Handling of chemicals / corrosive media with PVDF/PTFE
- PVDF and PP for applications with reduced purity requirements, such as PV production
- PP and PVC are typically used in industrial applications without purity requirements
- Various connections such as butt weld spigots, female threads, flare and clamp connections or union ends can be used depending on the requirement

# GEMÜ iComLine

Modular valve block solutions

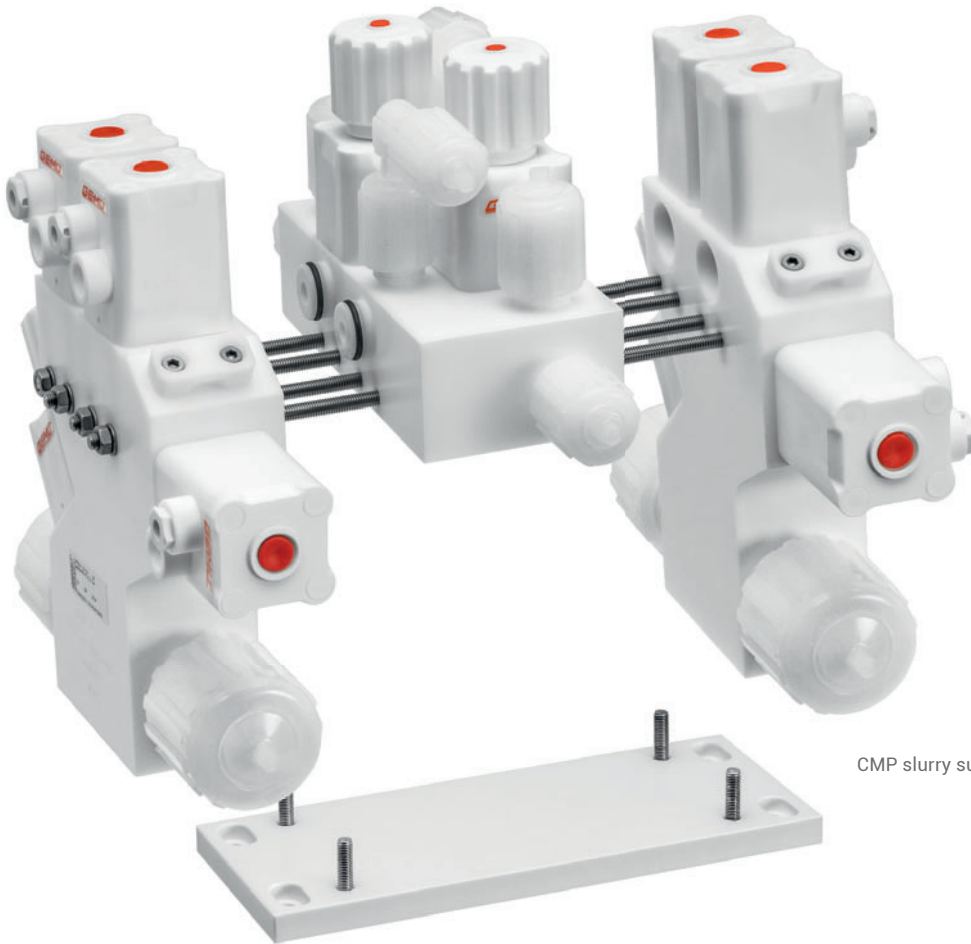

CMP slurry supply manifold

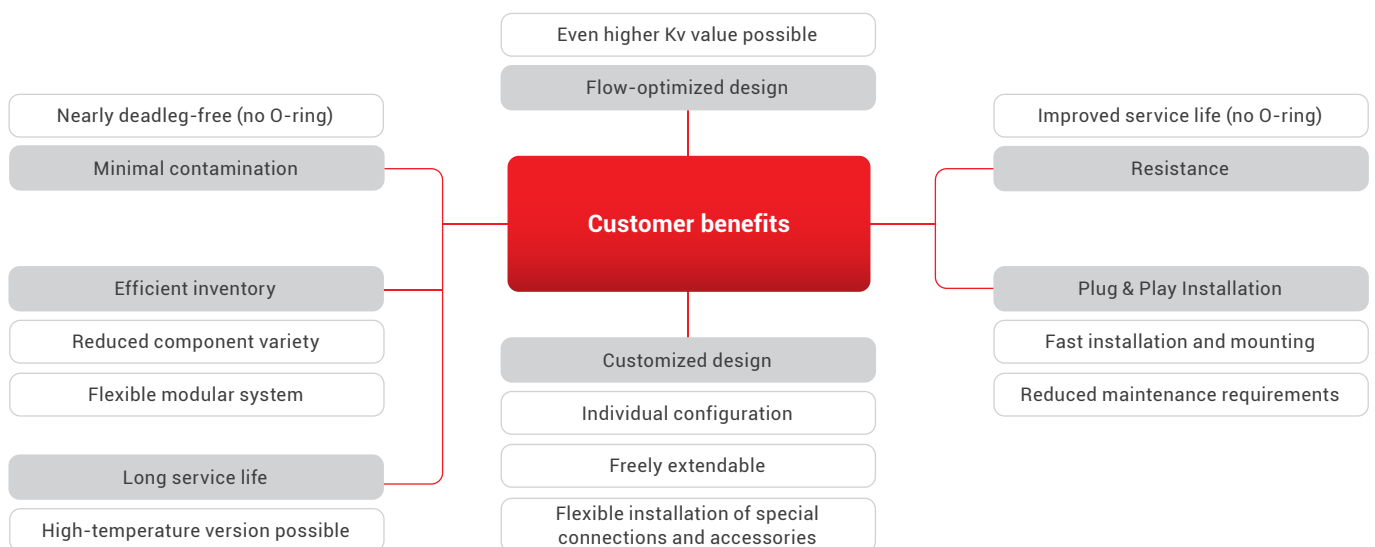

## Product highlights



### Features and advantages

- Flexible block concept for your individual plant design
- Even higher Kv value possible thanks to fewer redirections
- Option of implementing individual extensions
- Simple replacement of individual block sections
- Material savings compared to block made from one piece
- Efficient inventory

### Connecting the module blocks

#### O-ring joints

The individual module block segments are sealed with O-rings and held together by threaded rods.



#### Joints without O-rings

Sealing without O-rings makes it possible to reliably connect the individual module blocks and install special connections and accessories without additional elastomer seals. An overview of the advantages of joints without O-rings:

- Higher level of operational safety due to reduced leakage risk
- Long service life thanks to high chemical resistance
- Cost savings as no additional seals required
- More reliable installation
- Almost zero deadleg

Version 1

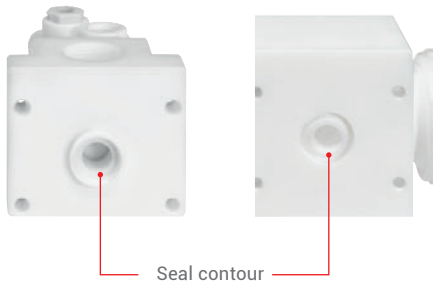

### Versions of O-ring free connections

The connection and compression of both contours is ensured, depending on requirements, using stainless steel screws or a thread directly machined in the GEMÜ PC50 multi-port valve block.

#### Version 1

Here, the two contours are compressed only using the four screws aligned around the sealing contour. The contours are pressed against each other due to the tightening torque of the screws.

Version 2

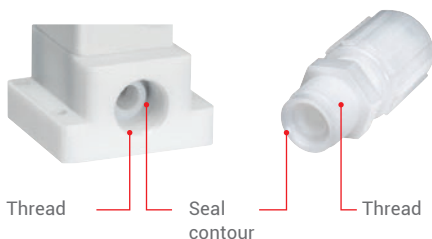

#### Version 2

In this version, the compression or pressure of the two seal contours is provided through a thread. The contours are pressed together through the rotary movement and the thread pitch.

# GEMÜ iComLine

## Ultra pure PTFE diaphragm globe valves

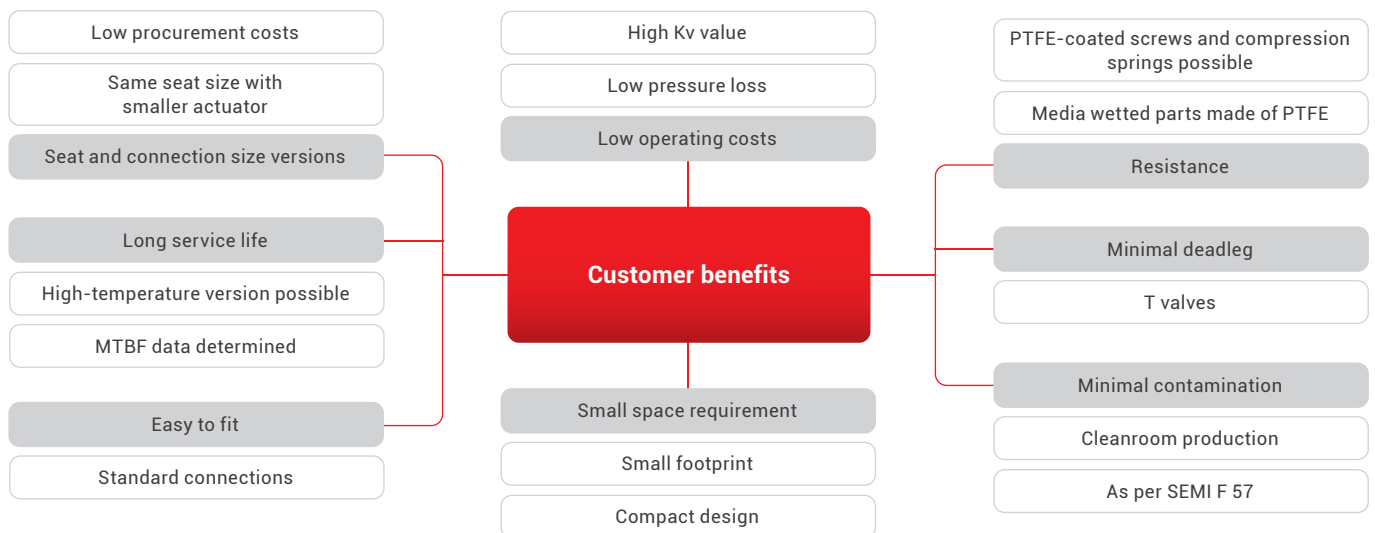
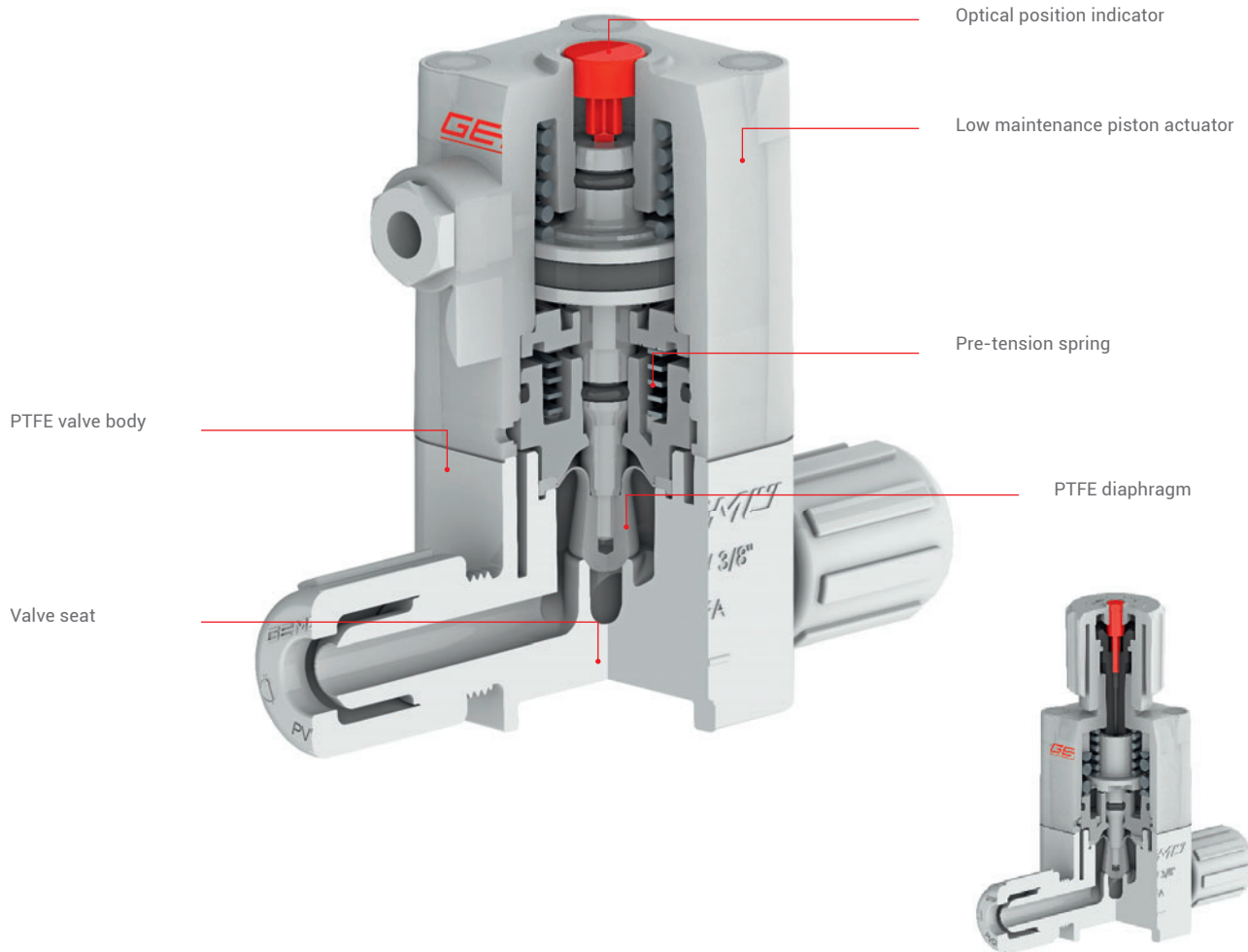



## Product range



GEMÜ C50 iComLine

### Pneumatic valve

- Low maintenance piston actuator
- Control functions: NC and NO
- All external actuator parts made of PVDF
- All media wetted parts made of PTFE
- Standard optical position indicator
- Stroke limiter available
- Integral mounting lugs
- Electrical position indicators and positioners can be fitted
- Also available as a high-temperature version



GEMÜ C51 iComLine

### Quarter-turn manual valve

- Toggle for operation
- Handwheel for setting a defined flow
- All external operator parts made of PVDF
- All media wetted parts made of PTFE
- Integral mounting lugs
- Available in operator sizes 0, 1 and 2



GEMÜ C57 iComLine

### Manual valve

- Ergonomic handwheel
- All external operator parts made of PVDF
- All media wetted parts made of PTFE
- Optical position indicator
- Integral mounting lugs

# GEMÜ iComLine

## Technical data and availability

### Range overview

<b>Operator:</b>	GEMÜ C50 pneumatic (NC, NO), GEMÜ C51 quarter-turn manual, GEMÜ C57 manual, external operator parts in PVDF Version with PTFE-coated screws and compression springs possible	<b>Valve body material:</b>	PTFE
<b>Connection:</b>	Flare, Pillar (Super Type 300, PrimeLock)	<b>Valve body configuration:</b>	2/2-way body
<b>Connection size:</b>	1/8" – 1 1/4"	<b>Diaphragm material:</b>	PTFE
		<b>Union nut material:</b>	PFA, PVDF, C-PFA

### Permissible operating conditions

#### Working media

Corrosive, inert, gaseous and liquid media – in particular high-purity media – which have no negative impact on the physical and chemical properties of the body and diaphragm material.

#### Standard seats:

- Operating temperature: max. 150 °C
- Operating pressure: max 6 bar

#### Modified seats:

- Operating temperature: max. 150 °C
- Operating pressure: max. 4,2 bar

#### High-temperature version:

- Operating temperature: max. 200 °C
- Operating pressure: max. 2 bar

### Accessories

#### GEMÜ C50

- Positioners: e.g. B. GEMÜ 1434 µPos, GEMÜ 1436 cPos
- Electrical position indicators: e.g. GEMÜ 1234, GEMÜ 1235, GEMÜ C12A
- Service tool for flare connections



Positioners:  
e.g. GEMÜ 1434 µPos,  
GEMÜ 1436 cPos



Electrical position indicators: e.g.  
GEMÜ 1234, GEMÜ 1235



Service tool for  
flare connections



Electrical position indicator GEMÜ  
C12A

## Product highlights

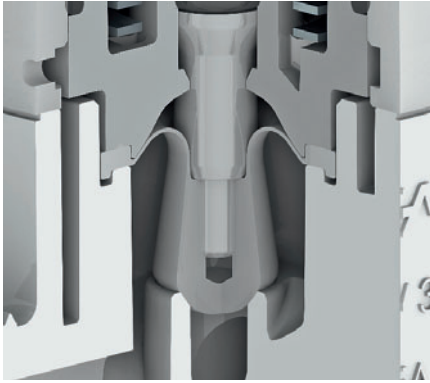

### Globe valve – compact design

- Globe valve design enables small footprint
- PTFE diaphragm (no other material/diaphragm back)
- Long service life – internally qualified switching cycles: Five million switching cycles
- Very suitable for control applications
- Very suitable for corrosive media
- Particularly suitable for use as dosing or filling valve

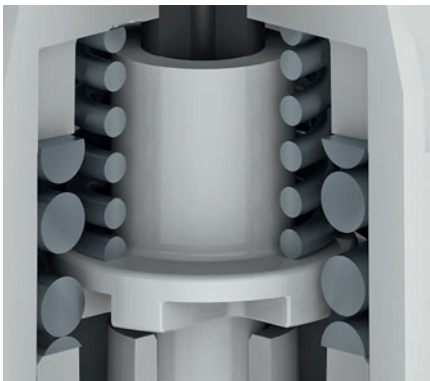

### Reliable tightness due to pre-tensioned spring

- Innovative solution offers extended areas of use
- Pre-tensioned spring presses the diaphragm against the body
- External leak tightness guaranteed, even with temperature fluctuations
- Material-specific flow properties are compensated for
- Long service life, even under difficult conditions of use



### Compact multi-port valve blocks

- Individual, customized and very flexible design
- Clearly reduced space requirement
- Valve body made from a single block or modular
- Simple implementation of individual extensions due to modular block design
- Versatile connection and actuator versions possible
- Various body materials possible
- Assemblies e.g. check valves and sensors can be integrated

# GEMÜ CleanStar

## Ultra-pure PFA diaphragm valves and PP diaphragm valves

Standard: Optical position indicator and stroke limiter

PFA valve body

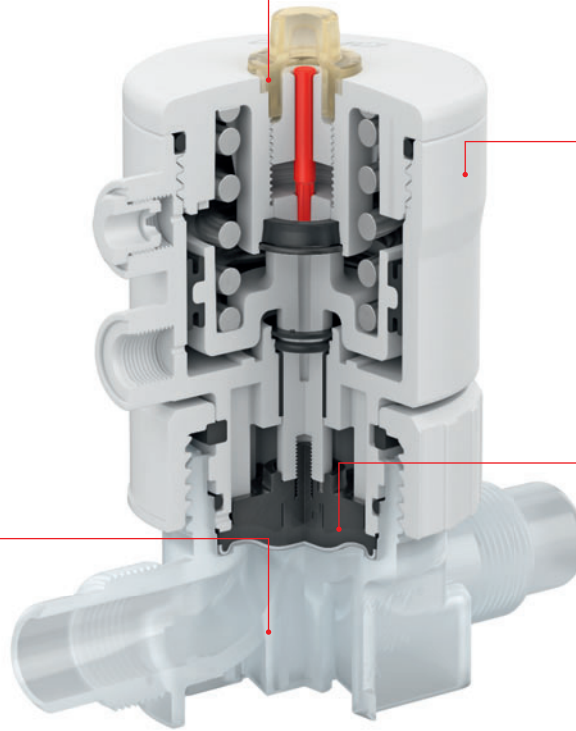

Low maintenance piston actuator

Shut off diaphragm (PTFE/EPDM)

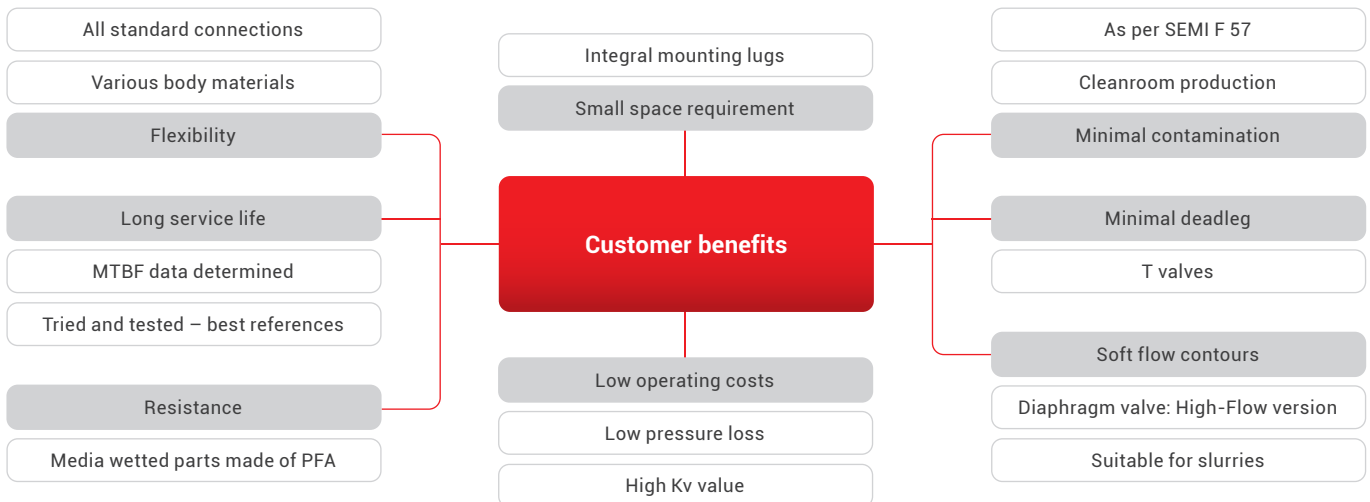

## Product range



### Pneumatic valve

- Low maintenance piston actuator
- Control functions: NC, NO, DA
- External actuator parts made of PVDF
- Standard stroke limiter and position indicator
- Union nut optionally made of ECTFE
- Electrical position indicator and process controller available



### Manual valve

- Ergonomic handwheel
- Metal-free
- External operator parts made of PVDF
- Standard seal adjuster and position indicator
- Union nut optionally made of ECTFE



### CleanStar SmartLine manual and pneumatic valves, version with PP valve bodies

- Low-cost CleanStar version
- For areas of application with lower purity requirements
- PTFE diaphragm
- Metal-free (GEMÜ C67 and GEMÜ C60 control function DA)
- Choice of valve bodies made of PP-R natural or PP-H grey
- Bodies with flare connections and DIN butt weld spigots
- Improved flow capability compared to PFA versions

# GEMÜ CleanStar

## Technical data

### Range overview

<b>Operator:</b>	GEMÜ C60 pneumatic, GEMÜ C67 manual, external operator parts made of PVDF, central union nut optionally in ECTFE	<b>Valve body material:</b>	PFA, PVDF, PP
<b>Connection:</b>	Flare connection, space saver, butt weld spigot, union end, PrimeLock®, Pillar®	<b>Valve body configuration:</b>	Straight through body, T body, V body
<b>Connection size:</b>	¼"-1 ¼" (depending on body configuration and connection type)	<b>Diaphragm material:</b>	PTFE face, EPDM back

### Permissible operating conditions

#### Working media

Corrosive, inert, gaseous and liquid media - particularly high purity media - which have no negative impact on the physical and chemical properties of the body and diaphragm material..

#### Material PFA:

- Operating temperature: max. 150 °C
- Operating pressure: max 6 bar

#### Material PP:

- Operating temperature: max. 80 °C
- Operating pressure: max. 6 bar

#### Material PVDF:

- Operating temperature: max. 120 °C
- Operating pressure: max. 6 bar

### Accessories

#### GEMÜ C60

- Positioners: e.g. GEMÜ 1434 µPos, GEMÜ 1436 cPos
- Electrical position indicators: e.g. GEMÜ 1234, GEMÜ 1235, GEMÜ C12A

#### GEMÜ C67

- Lock out device
- Service tool for actuator mounting
- Service tool for flare connections



Positioners:  
e.g. GEMÜ 1434 µPos,  
GEMÜ 1436 cPos



Electrical position indicators: e.g.  
GEMÜ 1234, GEMÜ 1235



Lock out device



Service tool for  
actuator mounting



Service tool for  
flare connections

## Product highlights

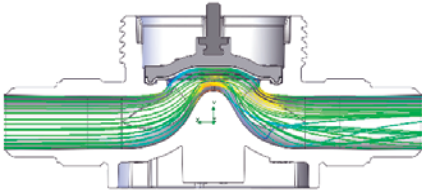

### High-Flow valve body

- Improved flow rate due to flow-efficient seat contour
- Low pressure losses
- Low-impact media handling due to gentle flow lines
- Longlife seat contour
- Up to 100% Kv value increase (depending on nominal size/connection)
- Same outer dimensions and connection to actuator as standard body



### 3-way valve with dual actuator concept

- Can be used as media mixing or manifold valve
- Actuators can be independently controlled
- Optional flow direction
- Minimal deadleg
- High Kv value
- Standard accessories can be fitted
- Lower priced than conventional versions



### Extensive T valve range

- T body design minimizes deadleg
- Saves using a T fitting
- Requires less space
- Reduced costs
- Coupling by space saver connection requires less space
- Ideal for manifolds in valve boxes
- Can be used as a sampling valve

# GEMÜ PurePlus

## Ultra-pure PVDF diaphragm valves

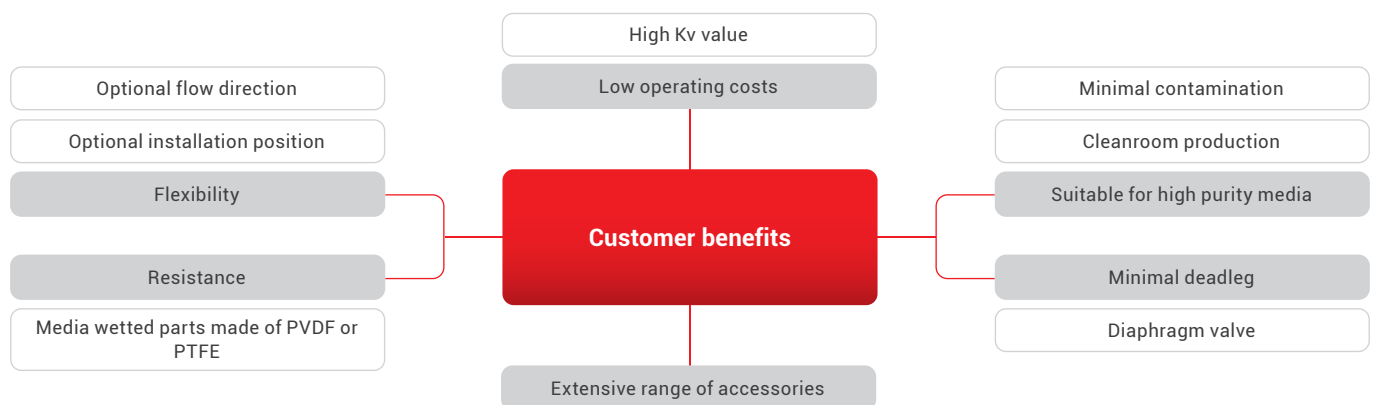



## Product range



GEMÜ 690 PurePlus

### Pneumatic valves with valve bodies in PVDF-HP

- Pneumatic actuators GEMÜ 600 or GEMÜ 690
- PTFE/EPDM diaphragm
- Valve body in PVDF
- 2/2-way or T valve body
- Butt weld spigots
- Nominal sizes DN 15 to 100



GEMÜ 677 PurePlus

### Manual valves with valve bodies in PVDF-HP

- Manual operator GEMÜ 677
- PTFE/EPDM diaphragm
- 2/2-way or T valve body
- Butt weld spigots
- Nominal sizes DN 15 to 100



GEMÜ 800 HP/850 HP PurePlus

### Variable area flowmeters in PVDF

- Float in PVDF with or without a magnet core
- Metering tube in PVDF
- Nominal sizes from DN 15 to 50
- Accessories for detection of measured values
- Dovetail sections for mounting of limit switches/instrument sensors
- Radially installable/removable

# GEMÜ 600 HP/677 HPW

## Ultra-pure PFA diaphragm valves

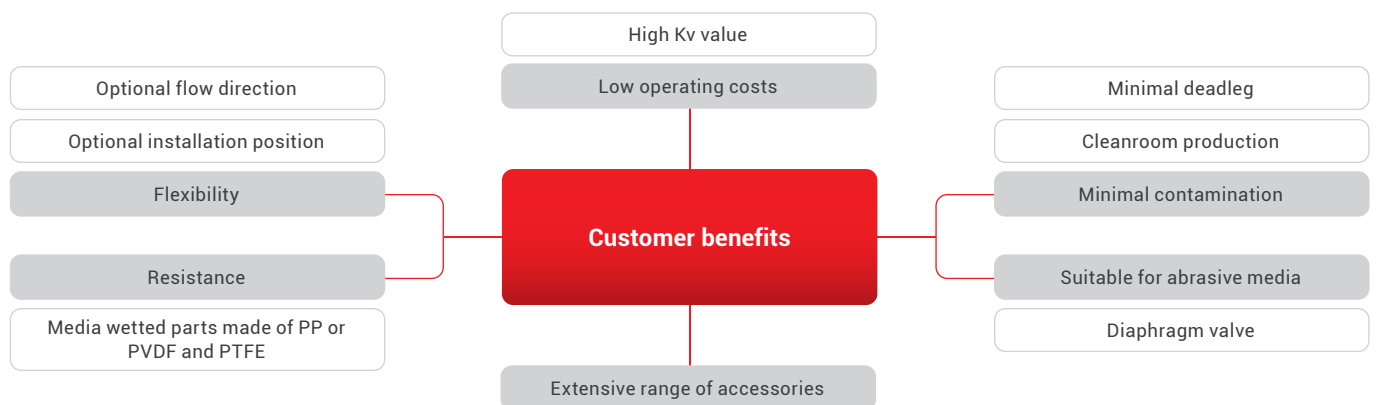

## Product range



GEMÜ 677 HP

### Manual and pneumatic valves with valve bodies in PFA-HP

- PTFE/EPDM diaphragm
- Valve body with PFA inliner and PVDF outliner (carbon-filled)
- 2/2-way valve body
- Butt weld spigots
- Size 1 ½" and 2" (DN 40 and 50)



GEMÜ 600 HP

### Pneumatic actuator

- Low maintenance piston actuator
- Control functions: NC, NO, DA
- Standard stroke limiter
- Standard manual override
- Integral optical position indicator



GEMÜ 677 HPW

### Manual operator

- Ergonomic handwheel
- Handwheel available in black or white
- Integral optical position indicator
- Assembled, tested and packaged in cleanroom
- Optional accessories on request

# GEMÜ HydraLine

Pressure measurement and monitoring of aggressive, corrosive and sensitive media

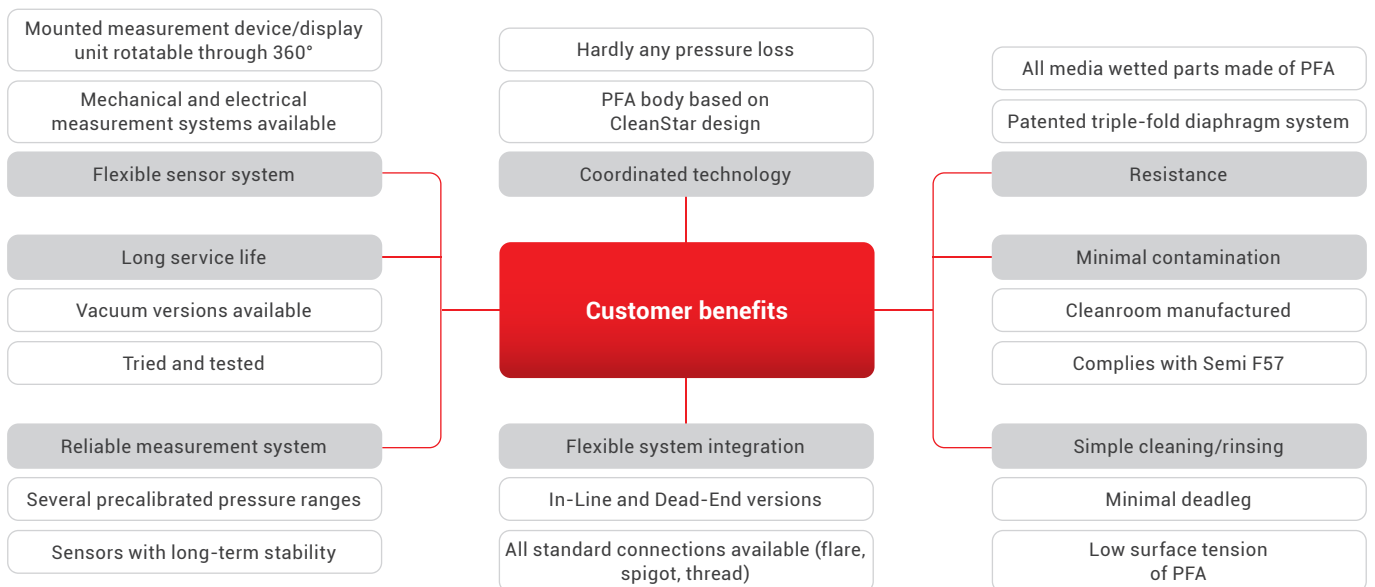
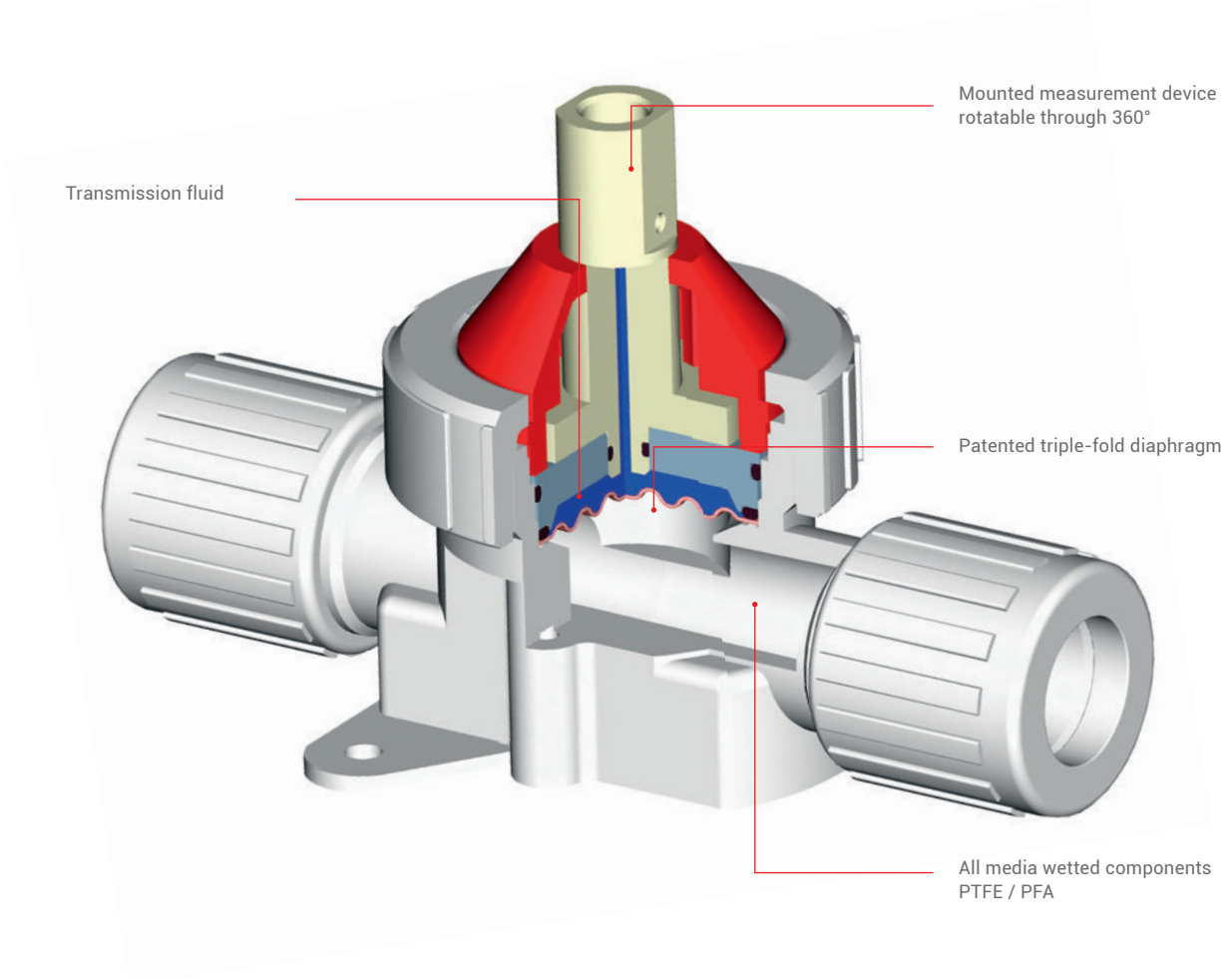

## Product range



### GEMÜ C30 Hydra-Gauge

The GEMÜ C30 Hydra-Gauge mechanical pressure measurement device is equipped with a high quality Teflon coated stainless steel gauge. The pipe type pressure gauge is actuated by the transmission fluid.

#### Your advantages at one glance:

- Teflon coated pressure gauge, rotatable through 360°
- Display inaccuracy 1.6%
- Patented triple-fold diaphragm
- Safe isolation of the process medium from the transmission fluid and the pipe type pressure gauge
- All media wetted components in PFA/PTFE



### GEMÜ C31 Hydra-Sensor

The GEMÜ C31 Hydra-Sensor pressure measurement device has a high-quality industrial pressure transmitter which is actuated by the transmission fluid.

#### Your advantages at one glance:

- High-quality industrial sensor (long-term stability)
- Various electrical connections available as standard (IP 65 or IP 67)
- Measurement inaccuracy 0.5%
- Patented triple-fold diaphragm
- All media wetted components made of high-quality PTFE or PFA



### GEMÜ C32 Hydra-Dry

The GEMÜ C32 Hydra-Dry electronic pressure measurement device is equipped with a ceramic capacitive sensor which is reliably isolated from the process medium by the vented triple-fold diaphragm.

#### Your advantages at one glance:

- No external metal parts
- High quality ceramic sensor, without transmission fluid
- Measurement inaccuracy 0.5%
- The sensor is directly actuated by the working medium without transmission fluid
- All media wetted components made of high-quality PFA or PTFE

# GEMÜ SonicLine

Flowmeters for aggressive, corrosive and pure media

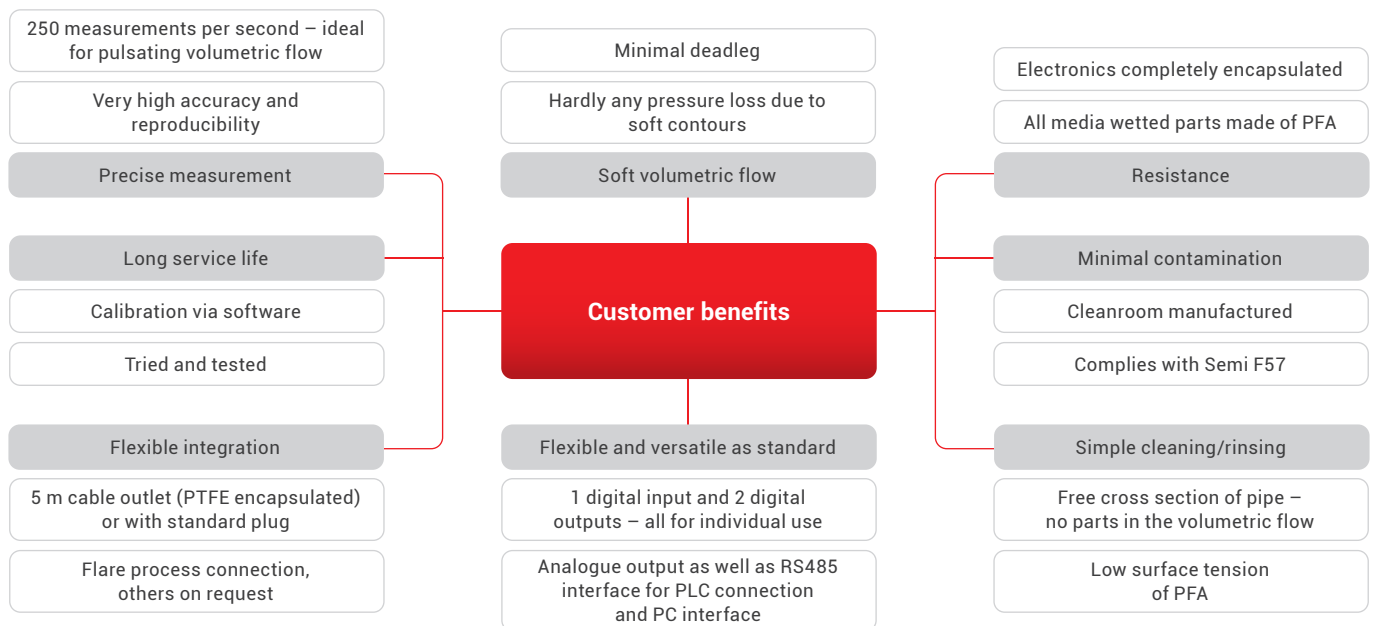
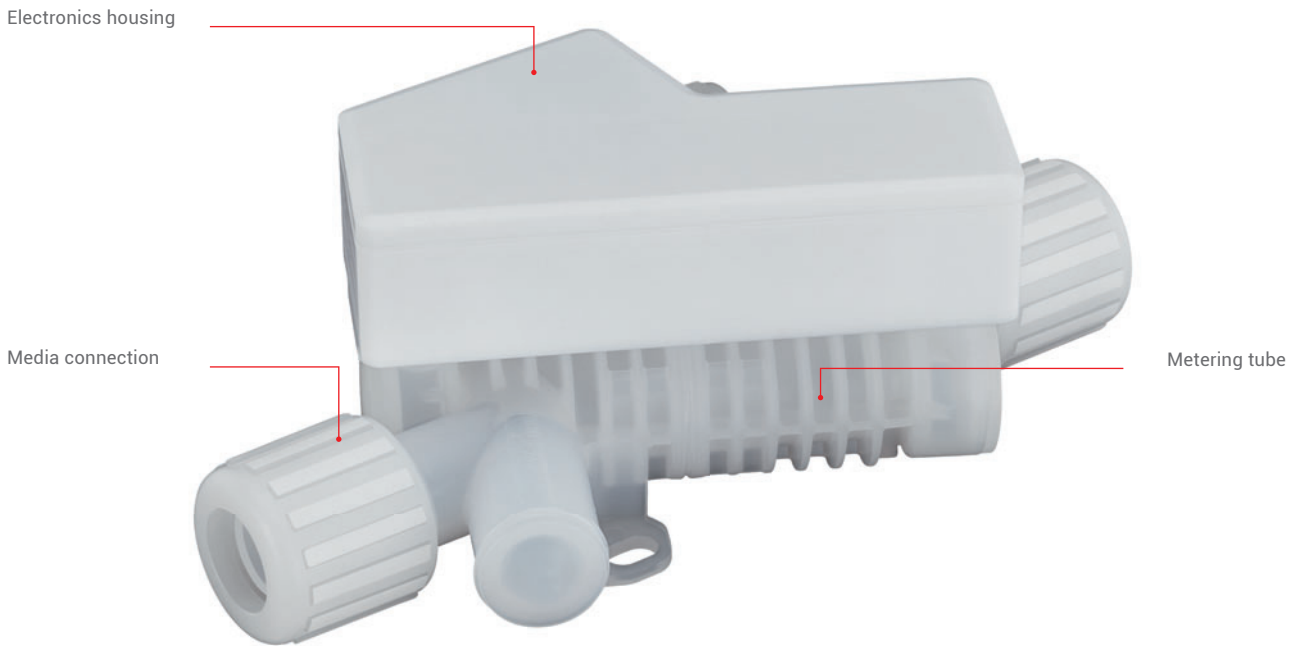

## Product range

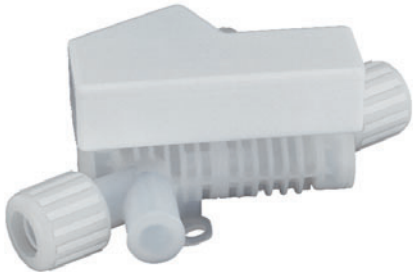

### SonicLine C38

The GEMÜ SonicLine C38 flowmeter is a contactless measurement device for liquid media with a high level of accuracy. As there are no moving or fixed parts in the measurement area the medium flows unhindered through the flowmeter. Therefore there is hardly any pressure loss and the device is easy to clean. All media wetted components are made of high quality PFA. The electronics housing is made of polypropylene and is completely encapsulated.

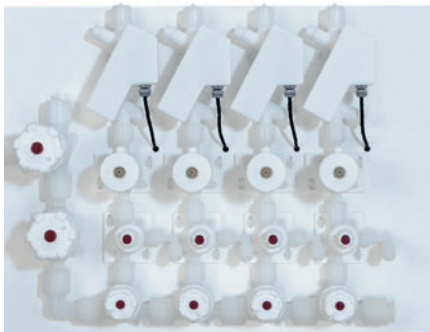

### SonicLine advantages at a glance

- Ideal for pulsating media flows
- Extensive PC software with analysis functions (multilingual)
- Reproducibility of measured values 0.5%
- Deviation of measured values  $\pm 1\%$
- Extremely fast detection of measured values (250 measured values/sec.)
- Empty pipe monitoring with alarm connection
- Digital inputs and outputs, can be individually assigned as standard
- Analogue output standard
- Process parameters freely programmable
- Space-saving installation

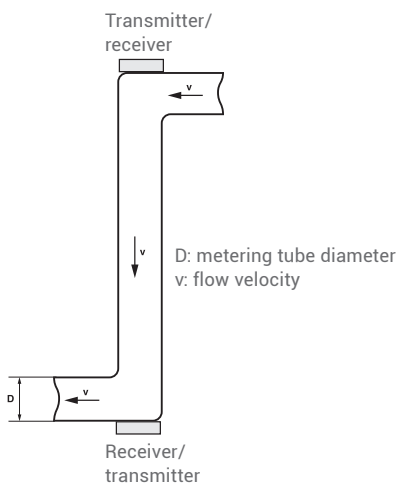

### Measurement principle and functionality

- Two sensors in opposite position reciprocally send and receive ultrasonic signals
- With a standing medium, both sensors receive the sent ultrasonic signals within the same phase, i.e. no difference in phase occurs
- With a flowing medium a phase shifting takes place
- This phase difference is directly proportional to the flow velocity ( $v$ )
- The flow volume is determined from the flow velocity and the pipe diameter ( $D$ )

# GEMÜ FlareStar/TubeStar

Ultra-pure PFA fitting and tubing system

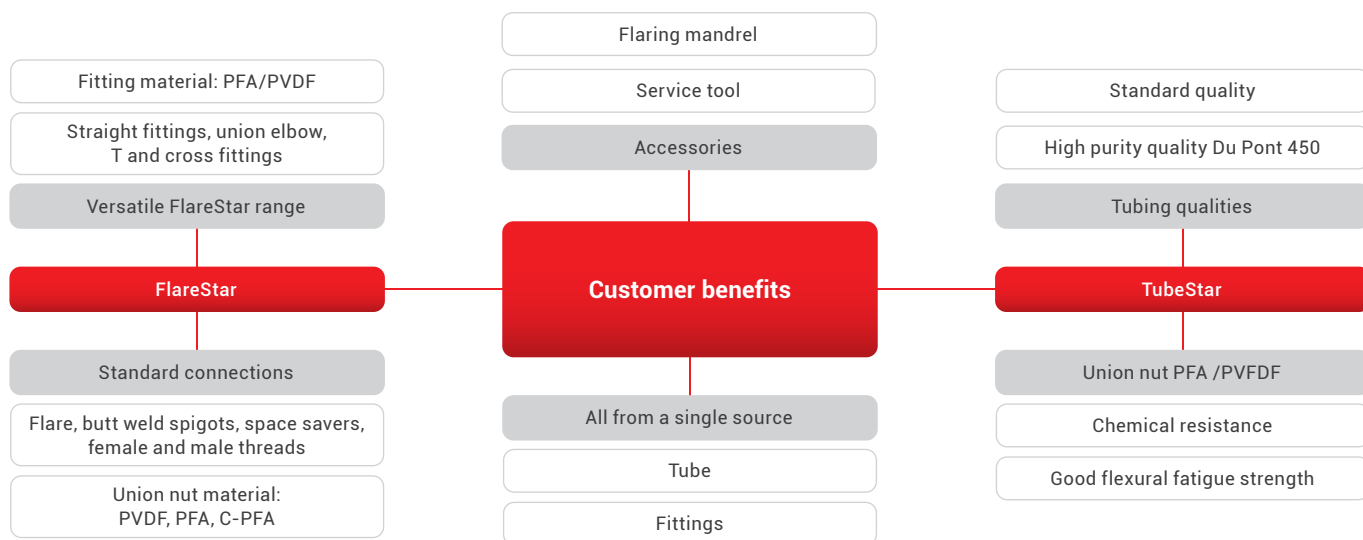
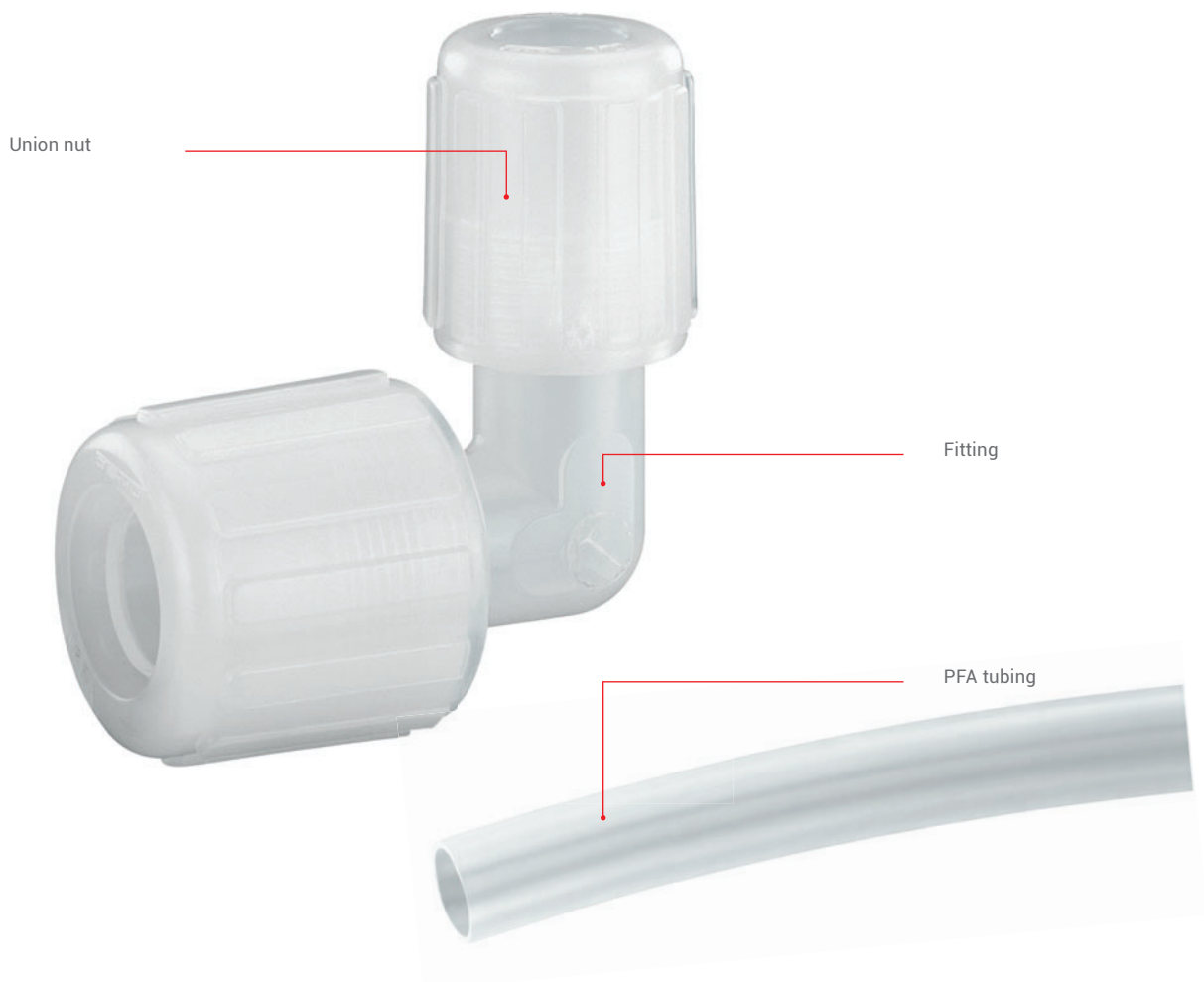



## Product range



### FlareStar – high-purity PFA tube and weld fittings

The FlareStar product range includes numerous tube and weld fitting versions such as union elbow, union tee, straight fittings.

- Tube fittings are available in sizes ¼", ⅜", ½", ¾", 1" and 1¼"
- Weld fittings are available in sizes ¼", ½", ¾", 1" and 2"
- The fittings are made of Du Pont 440 HP material



### TubeStar – high-purity and standard PFA tubing

The TubeStar PFA tubing range comprises tubing spools and straight tube pieces in high-purity and standard quality.

- All available tube sizes are ¼", ⅜", ½", ¾", 1" and 1¼"
- All tube lengths are available in 10 m, 20 m, 50 m, 100 m spools as well as in 6 m straight tube pieces
- The HP tubes are made of Du Pont 450 HP material
- Special lengths, special sizes available on request



### Accessories and tools

#### GEMÜ 1098

- Flaring mandrel
- Assembly tool for PFA-HP flare connection

#### GEMÜ CF

- Service tool for FlareStar union nuts

# GEMÜ Check Valve CV

Metal-free, ultra-pure PTFE check valve

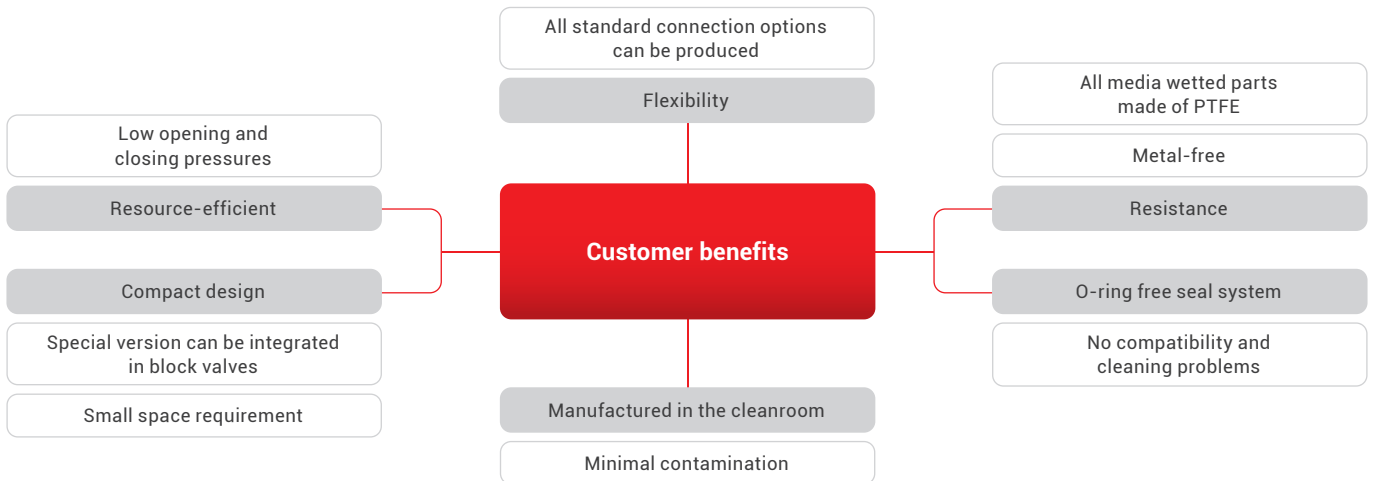
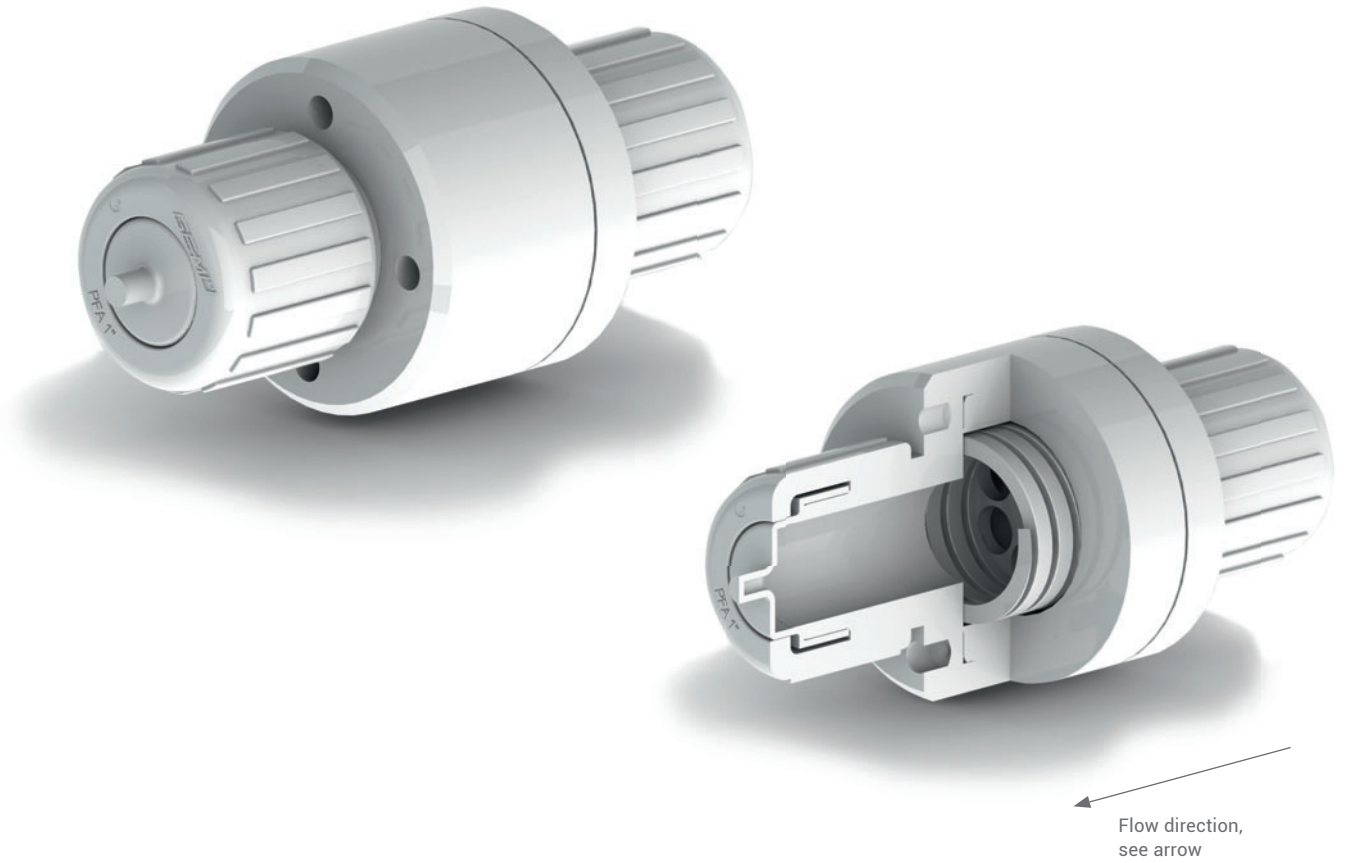

## Product range

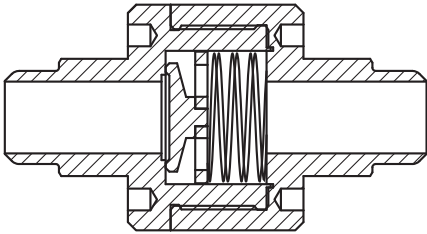

### Standard CVFF

- All media wetted parts made of PTFE
- Machined PTFE spring
- Available in sizes from 1/4" to 1"
- Flare connection with optional PVDF, PFA or CPFA union nuts
- Low opening and closing pressures

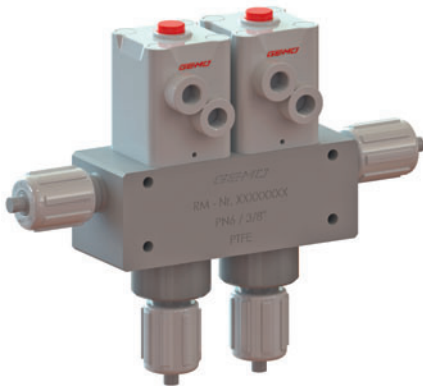

### Block integration

Versions A (CVFU) and B (CVUF) can be integrated in GEMÜ PC50 iComLine multi-port valve blocks.

Version A: CVFU

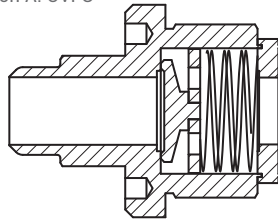

Version B: CVUF

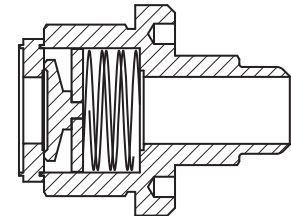

### Versions

All standard connection options NPT, flare, PrimeLock, pillar can be produced. Different connections can be combined with each other – e.g. Flare-Pillar, Flare-NPT.

# Stainless steel components

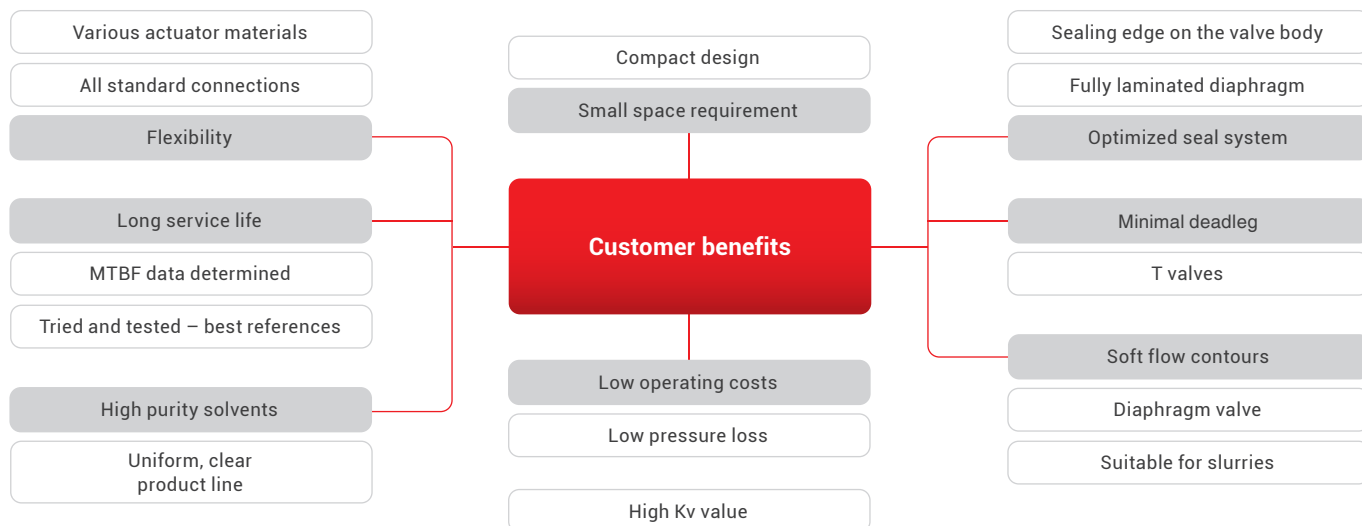
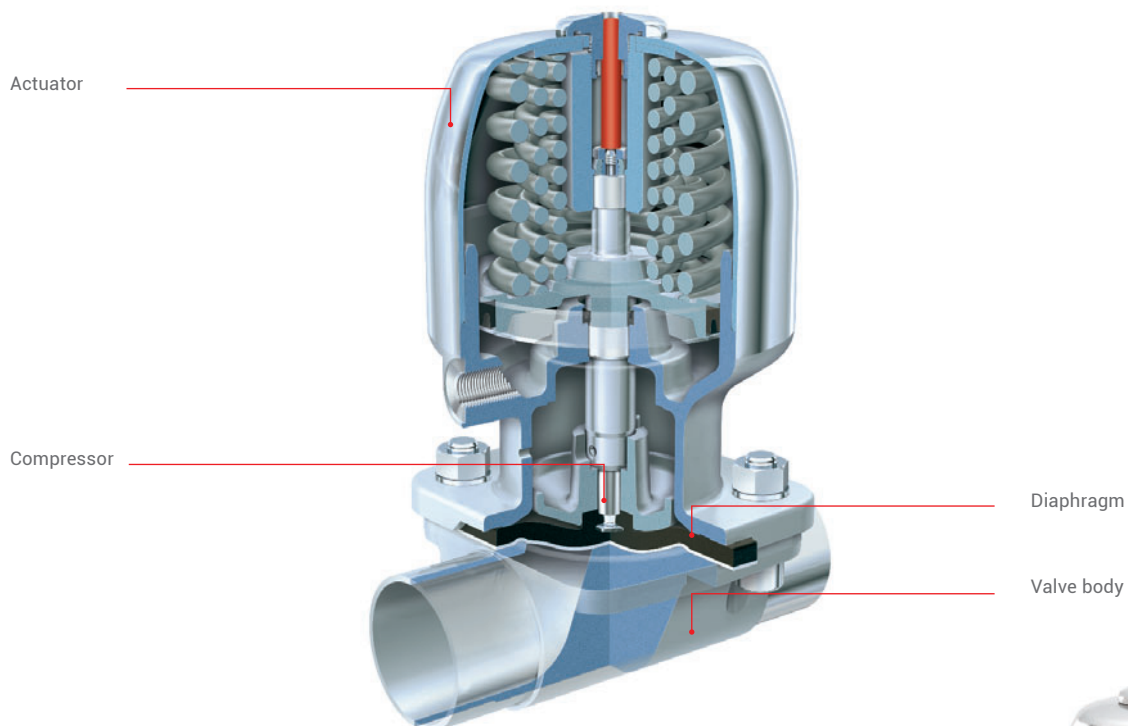

## Stainless steel components



GEMÜ 673

### Stainless steel valves with plastic actuator/operator

- Pneumatic actuator GEMÜ 695
- Manual operator GEMÜ 653 and 673
- PTFE/EPDM diaphragm
- Valve bodies made of stainless steel
- Plastic actuators/operators
- Various connection options
- Nominal sizes from DN 15 to 50



GEMÜ 650 BioStar

### High-quality stainless steel versions

- Pneumatic actuator GEMÜ 650
- Manual operator GEMÜ 654
- PTFE/EPDM diaphragm
- Valve bodies made of stainless steel
- Stainless steel actuators/operators
- Various connection options
- High-quality design



GEMÜ P600 stainless steel

### Implementation of compact manifolds

- Individual, customized and compact design
- Requires significantly less space
- Valve body machined from one block of material
- Versatile connection and actuator versions possible
- Assemblies and sensors can be integrated
- Shorter installation time

# Overview of GEMÜ products

Industrial components for water and waste water treatment



## Butterfly valves in metal and plastic

- Available up to DN 1600
- Advanced seal design – even for larger diameters
- Modular construction
- Extensive applications using a variety of materials
- Also available with highly resistant seal materials with high temperature and corrosion resistance
- Other valve types available, which are also suitable for High-Purity applications



## Plastic diaphragm valves

- Available up to DN 100
- Compact and lightweight construction (reduced control air volume)
- Smooth surfaces (reduced dirt entrapment)
- Integral optical position indicator



## Plastic ball valves

- Pneumatically operated
- Available up to DN 100
- Good flow capability
- All media wetted parts and actuator housing are made of plastic
- Other ball valve types with manual operator or motorized actuator are available

## Instrumentation and accessories

### Positioners and process controllers

Intelligent positioners and process controllers for linear and quarter-turn actuators, remote mounting possible, fast mounting and commissioning due to speed-<sup>AP</sup> function.



### Electrical position indicators

Electrical position indicators in a wide range of versions, manual/automatic stroke adjustment, depending on version also with self-learning speed-<sup>AP</sup> function, LED display and optional field bus connection.



### Intelligent combi switchbox

Combi switchbox for linear actuators, integrated position feedback, manual/automatic stroke adjustment, integrated pilot valve, optional field bus connection.



### Solenoid valves

Particularly suitable for clean liquid and gaseous, inert and corrosive media, depending on the version. Solenoid valves are designed for fast cycle duties and are particularly suitable for dosing applications.



### Flowmeters

Flowmeters with various functional principles for inert and corrosive liquids and gases. Depending on version, mounting of electrical limit switches and instrument sensors possible as well as field bus connection.



### Accessories

Available accessories include stroke limiters and optical position indicators, various mounting kits, control air adapters and NAMUR mounting brackets, plugs and cable connectors, travel sensors for controllers and many other items.



# GEMÜ Green Engineering

Focus on environment, customer benefits and cost efficiency



GEMÜ multi-port valve block – customized solutions for a cost-effective plant design



GEMÜ C60 CleanStar in HighFlow version – optimized valve body for cost-effective use

Whether using 50% less material for the first GEMÜ valve compared with conventional valves or the launch of a recycling system in 1979: Right from the start, GEMÜ's planning and construction was more compact and used fewer resources than any other manufacturer, and the company was concerned about the environment long before it attracted so much media attention.

### A tradition of environmental awareness

Since 2011 the Green Engineering initiative has combined all the GEMÜ Group activities in order to ensure more sustainable, environmentally friendly corporate activity. To this end, all manufacturing processes are optimized in order to minimize the use of resources. At the same time, products are developed that satisfy important sustainability criteria. Further projects for using new technologies and introducing innovative collaborations will be supported or even planned and implemented.

### 1. Clean production

As part of DIN EN ISO 14001, GEMÜ sets itself definite environmental targets which are checked regularly. They have always been and will continue to be successfully implemented.

### 2. Clean products

The Green Engineering concept is codified in the GEMÜ design guidelines. Even during the development process, ecological factors must be given due consideration.

### 3. Clean projects

In 2011, the CLEAN PROJECTS sector was established by GEMÜ Managing Director Gert Müller. Its main focus is on the use of electric mobility and primarily ecological building within the growing group of companies.

GEMÜ not only supplies, but is also an end consumer of sustainable energy and mobility solutions.



Combined heat and power plant in the European Production and Logistics Centre



Photovoltaic panels in the European Production and Logistics Centre



Vehicles – GEMÜ electric shuttle



# It's all about the right service

Every application is different and therefore sets very different requirements for the measurement and control systems. In addition, numerous valve designs are available to implement complex process sequences. It's easy to lose sight of everything.

To ensure that our customers can focus on the big picture, we provide detailed support on a case-by-case basis. Namely, in selecting the right components.

Taking into account all relevant operating parameters, such as pressure, temperature and the properties of the medium to be controlled, we always develop and calculate the right configuration. Our specialized and experienced team of applications technicians and engineers ensures

that precisely the right valves for the particular service life and performance features are selected. And the focus is always on creating the optimal plant for our customers' work processes.

This is supplemented with a multi-layered training system. Our experienced trainers not only teach basic knowledge, but also expert knowledge about valves and applications. Whether at GEMÜ's headquarters or directly at the customer's premises as an in-house training course.

Furthermore, GEMÜ supports its customers with repair work, commissioning and troubleshooting, if required. A dedicated repair and service team is available for these tasks.





## Manufacturing and assembly in the cleanroom

The production of GEMÜ high-purity products is subject to a modern, continuous quality management system, which guarantees a consistent and reproducible level of quality in accordance with the customer's requirements.

The cleanroom plant uses the very latest manufacturing technologies and achieves cleanroom quality in accordance with ISO class 8 (in operation) as well as GMP class C.

### Cleanroom capacity

- Approx. 1800 m<sup>2</sup> cleanroom ISO 8 (in operation) and GMP Class C for injection moulding
- Approx. 1000 m<sup>2</sup> cleanroom ISO 8 (in operation) and GMP class C for assembly technology; locally, this area can be increased to ISO 6 (in operation)



# Permanently controlled quality

## Purity, quality, safety

To guarantee the highest purity all high purity products are manufactured, cleaned, assembled and packed under cleanroom conditions. GEMÜ products are subject to continuous quality management. To this end, all processes are continuously monitored. The internal tests are also supplemented by testing at external testing institutes.

### Raw material



Preliminary test and reference sampling

### Manufacture



Processing under cleanroom conditions

### Cleaning

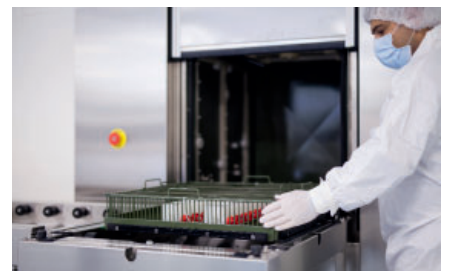

Multi-stage cleaning

### Packaging



Double packaging and identification for complete traceability



### Assembly and testing



Assembly in the cleanroom and 100 % testing (tightness etc.)

## GEMÜ Quality Loop

- Use of specified/controlled raw materials, continuous incoming inspection
- Reference sampling for traceability
- SPC – statistic process control
- Continuous further development for staff
- Voluntary supervision
- Customer audits
- Continuous improvement process
- Certified in accordance with ISO 9001:2008







# Product overview

## Valves



Series / Type		GEMÜ CleanStar C60 / C67	GEMÜ iComLine C50 / C51 / C57	GEMÜ iComLine PC50 (M blocks)	GEMÜ PurePlus 600 / 677 / 690	1 1/2" and 2" 600 / 677
Design		Diaphragm valve	Globe valve	Globe valve	Diaphragm valve	Diaphragm valve
Pressure range*		0 to 6 bar	0 to 6 bar	0 to 6 bar	0 to 6 bar (677: 0–10 bar)	0 to 6 bar
Temperature		max. 150 °C	max. 150 °C	max. 150 °C	max. 90 °C (677: max. 120 °C)	max. 90 °C
Nominal size		DN 4 to 25 (1/4"–1 1/4")	DN 4 to 25 (1/4"–1 1/4")	DN 4 to 25 (1/4"–1 1/4")	DN 15 to 100	DN 40 to 50
Operator	manual	•	•	•	•	•
	pneumatic	•	•	•	•	•
	motorized					
Body material	PFA	•				•
	PTFE		•	•		
	PVDF	•		•	•	
	PP	•		•		
	PVC			•		
	Stainless steel			•		
Seal material	PTFE	•	•	•	•	•
	FPM					
Connection	Flare	•	•	•		
	Pillar		•	•		
	Weld	•		•	•	•
	Thread			•		
	Other			•		
Positioners		•	•	•	•	•
Electrical position indicators		•	•	•	•	•
Chemical handling		•	•	•	•	•
Water treatment		•	•	•	•	•
Waste water treatment		•	•	•	•	•
Wet process equipment		•	•	•	•	•
Slurry supply		•	•	•	•	•
Solvent supply		•	•	•		•

\* relative pressure

		Measurement systems			Connection technology		
							
GEMÜ stainless steel valves 601 / 602 / 605 / 612 / 625 / 650 / 654 / 673 / 687 / 695		GEMÜ Check Valve CV	GEMÜ HydraLine C30 / C31 / C32	GEMÜ SonicLine C38	GEMÜ flowmeters 823 / 824 / 833 / 834 / 873 / 883	GEMÜ TubeStar tubing	GEMÜ FlareStar fittings
Diaphragm valve	Check valve	Pressure measurement device	Ultrasonic flowmeter	Variable area flowmeter	Spools and straight tube pieces	Various versions	
0 to 6 bar	0 to 6 bar	0 to 6 bar	0 to 6 bar	0 to 10 bar	0 to 6 bar	0 to 6 bar	
max. 150 °C	max. 90 °C	max. 60 °C	max. 60 °C	max. 90 °C	max. 150 °C	max. 150 °C	
DN 8 to 100	DN 4 to 25 (¼"-1¼")	DN 4 to 25 (¼"-1¼")	DN 6 to 20 (¾"-1")	DN 15 to 50	DN 4 to 25 (¼"-1¼")	DN 4 to 50 (¼"-2")	
•							
•							
		•	•		•	•	
	•	•					
				•			
•							
•							
•							
	•	•	•			•	
•				•		•	
						•	
				•		•	
	•	•	•		•	•	
•	•	•	•		•	•	
•	•	•	•		•	•	



# Worldwide presence

## AUSTRALIA

GEMÜ Australia Pty. Ltd  
Unit 4 - 8/10 Yandina Road  
West Gosford, NSW 2250  
Phone: +61-2-43 23 44 93  
Fax: +61-2-43 23 44 96  
mail@gemu.com.au

## AUSTRIA

GEMÜ GmbH  
Europaring F15 401  
2345 Brunn am Gebirge  
Phone: +43 2236 30 43 45-0  
Fax: +43 2236 30 43 45-31  
info@gemue.at

## BELGIUM

GEMÜ Valves bvba/sprl  
Koning Albert 1 laan, 64  
1780 Wemmel  
Phone: +32 2 702 09 00  
Fax: +32 2 705 55 03  
info@gemue.be

## BRAZIL / SOUTH AMERICA

GEMÜ Indústria de Produtos  
Plásticos e Metalúrgicos Ltda.  
Rue Marechal Hermes, 1141  
83.065-000 São José dos Pinhais  
Paraná  
Phone: +55-41-33 82 24 25  
Fax: +55-41-33 82 35 31  
gemu@gemue.com.br

## CANADA

GEMÜ Valves Canada Inc.  
2572 Daniel-Johnson Boulevard  
Laval, Quebec  
H7T 2R8  
Phone: +1-450-902-2690  
Fax: +1-404-3 44 4003  
info@gemu.com

## CHINA

GEMÜ Valves (China) Co., Ltd  
No.518, North Hengshahe Road  
Minhang District, 201108  
Shanghai  
Phone: +86-21-2409 9878  
info@gemue.com.cn

## DENMARK

GEMÜ ApS  
Industriparken 16-18  
2750 Ballerup  
Phone: +45 70 222 516  
info@gemue.dk

## FRANCE

GEMÜ S.A.S  
1 Rue Jean Bugatti  
CS 99308 Duppigheim  
67129 Molsheim Cedex  
Phone: +33-3 88 48 21 00  
info@gemu.fr

## INTERCARAT

1 Rue Jean Bugatti  
CS 99308 Duppigheim  
67129 Molsheim Cedex  
Phone: +33-3 88 48 21 20  
sales@intercarat.com

## GERMANY

GEMÜ Gebr. Müller GmbH & Co. KG  
Fritz-Müller-Straße 6 - 8  
74653 Ingelfingen-Criesbach  
Postfach 30  
74665 Ingelfingen-Criesbach

Phone: +49 (0)7940-12 30  
Fax: +49 (0)7940-12 31 92  
(Domestic)  
Fax: +49 (0)7940-12 32 24 (Export)  
info@gemue.de

Inevvo solutions GmbH & Co. KG  
Fritz-Müller-Platz 1  
74676 Niedernhall-Waldzimmern  
Phone: +49 (0)7940-12 38 681  
info@inevvo-solutions.com

## GREAT BRITAIN

GEMÜ Valves Ltd.  
10 Olympic Way  
Birchwood, Warrington  
WA2 0YL  
Phone: +44-19 25-82 40 44  
Fax: +44-19 25-82 80 02  
info@gemu.co.uk

## HONG KONG

GEMÜ (Hong Kong) Co., Ltd.  
Room 2015, Tower B,  
Regent Centre,  
70 TA Chuen Ping Street  
Kwai Chung, N.T., Hong Kong  
P.R. China  
Phone: +852 6873 8280  
Fax: +852 6873 8280  
info@gemue.com.cn

## INDIA

GEMÜ Branch Office India  
Room Number 135,  
1st Floor, 101-104, B-Wing,  
GCP Business Centre  
Opp. Memnagar Fire Station  
Vijay Cross Road  
Ahmedabad - 380 014  
Phone: +91-79-6134 4423  
Fax: +91-79-25450439  
sales@gemu.in

## INDONESIA

GEMÜ Valves Pte Ltd  
(Indonesia Representative Office)  
Rukan Mangga Dua Square  
Block F17, 2nd Floor  
Jl. Gunung Sahari Raya No. 1  
Jakarta Utara 14420  
Indonesia  
Phone: +62 (21) - 6231 0035  
Fax +62 (21) - 2907 4643  
info@gemu.co.id

## IRELAND

GEMÜ Ireland Ltd  
15 Eastgate Drive  
Eastgate Business Park  
Little Island  
Co. Cork  
Phone: +353 (0)21 4232023  
Fax: +353 (0)21 4232024  
info@gemu.ie

## ITALY

GEMÜ S.r.l.  
Via Giovanni Gentile, 3  
20157 Milano  
Phone: +39-02-40044080  
Fax: +39-02-40044081  
info@gemue.it

## JAPAN

GEMÜ Japan Co., Ltd.  
2-5-6, Aoi, Higashi-ku,  
Nagoya, Aichi, 461-0004  
Phone: +81-52-936-2311  
Fax: +81-52-936-2312  
info@gemu.jp

## MALAYSIA

GEMÜ VALVES MALAYSIA  
SDN. BHD.  
D-2-01, Capital 4,Oasis Square  
No. 2, Jalan PJU 1A/7A  
Ara Damansara  
47301 Petaling Jaya  
Selangor Darul Ehsan  
Phone: +(603)- 7832 7640  
Fax: +(603)- 7832 7649  
info@gemu.com.sg

## MEXICO

GEMÜ Valvulas S.A. de C.V.  
German Centre,  
Av. Santa Fe No. 170 – OF. 5-1-05  
Col. Lomas de Santa Fe,  
Del. Alvaro Obregon  
01210 Mexico, D.F.  
Phone: +52 55 7090 4161  
+52 55 7090 4179

## RUSSIA

OOO „GEMÜ GmbH“  
Uliza Shipilovskaya, 28A  
115563, Moskau  
Phone: +7(495) 662-58-35  
Fax: +7(495) 662-58-35  
info@gemue.ru

## SINGAPORE

GEMÜ Valves PTE. LTD.  
25 International Business Park  
German Centre #03-73/75  
Singapore 609916  
Phone: +65-65 62 76 40  
Fax: +65-65 62 76 49  
info@gemu.com.sg

## SOUTH AFRICA

GEMÜ Valves Africa Pty. Ltd  
Cnr Olympic Duel Avenue  
And Angus Crescent,  
Northlands Business Park  
(Stand 379),  
New Market Road  
Randburg  
Phone: +27 11 462 7795  
Fax: +27 11 462 4226  
info@gemue.co.za

## SWEDEN

GEMÜ Armatur AB  
Heljesvägen 8  
437 36 Lindome  
Phone: +46-31-996500  
order@gemu.se

## SWITZERLAND

GEMÜ GmbH  
Seetalstr. 210  
6032 Emmen  
Phone: +41-41-7 99 05 05  
Fax: +41-41-7 99 05 85  
info@gemue.ch

GEMÜ Vertriebs AG  
Lettenstrasse 3  
6343 Rotkreuz  
Phone: +41-41-7 99 05 55  
Fax: +41-41-7 99 05 85  
vertriebsag@gemue.ch

## TAIWAN

GEMÜ Taiwan Ltd.  
9F.-5, No.8, Ziqiang S. Rd.  
Zhubei City  
Hsinchu County 302,  
Taiwan (R.O.C.)  
Phone: +886-3-550-7265  
Fax: +886-3-550-7201  
office@gemue.tw

## UNITED STATES

GEMÜ Valves Inc.  
3800 Camp Creek Parkway  
Suite 120, Building 2600  
Atlanta, Georgia 30331  
Phone: +1-678-5 53 34 00  
Fax: +1-404-3 44 93 50  
info@gemu.com

Ergänzend hierzu besitzt  
GEMÜ ein globales Partner-  
netzwerk.

Kontakt Daten:  
[www.gemu-group.com/  
de\\_DE/kontakte](http://www.gemu-group.com/de_DE/kontakte)



 GEMÜ manufacturing site

 GEMÜ subsidiary

