

Herculine 2000 Series Actuators

Specification, October 2019



Overview

Honeywell's **HercuLine® 2000 series** actuators are low torque, precision electric actuators incorporating all of the easy-to-use, high quality, and reliable features of the traditional **HercuLine®** actuators.

Ensuring processes operate at maximum efficiency, with minimal downtime, and lowest lifetime cost requires precision and high reliability **HercuLine®** actuators. They are industrial rated and engineered for very precise positioning of dampers and valves. They perform especially well in extremely demanding environments requiring continuous duty, high reliability, and low maintenance.



HercuLine® 2000 actuators are used in on/off power to open/close or position proportional with 135 or 10K Ohms feedback applications.



HercuLine® 2001 and 2002 Smart actuators are used in current proportional or digital control applications. Access to all actuator parameters for real-time business and maintenance decisions is standard through Modbus RTU, local display, or via **HercuLink®** Palm PDA software.

HercuLine® 2002 actuators have additional standard features such as non-contact position sensing and slidewire emulation output.

HercuLink® software enables calibration, configuration, and access to maintenance data using your Palm PDA.



Smart Features – HercuLine® 2001 & 2002

- **RS485/Modbus RTU Communication** - Modbus RTU communication is standard allowing seamless networking of Honeywell control products
- **Alarm Functions** – Alarms may be assigned to relay outputs or may be accessed through the Modbus network. Alarms can be triggered from stall, temperature limits, motor cycle count, out of automatic mode, digital input, position, input failure, position sensor failure, power up failure, and more.
- **Characterization** – Programmable linear, equal percentage, quick opening, or user configured 20-point characterization

- **Failsafe** – the actuator can be programmed to drive open, closed, remain in-place, or drive to a user specified position on loss of input
- **Split range operation** – programmable and infinitely adjustable.
- **Factory Calibration** – stored in non-volatile memory and can be restored at any time.
- **Digital Input Override** – A digital input is provided so that can be programmed to drive the actuator open, closed, remain in-place, or to a user specified position on contact closure for emergency situations.
- **Health Monitoring** – A standard feature on all **HercuLine®** Smart actuators accumulates information about actuator operation. The information then can be used to evaluate and determine predicted or scheduled maintenance periods. Parameters monitored are accumulated stall time, exceeded thermal operating rating of the actuator, and number of motor starts in a region of travel, total travel and current actuator travel.
- **Input Filter Setting** – Four programmable combinations - none, spike, low pass, or spike + low pass filter.
- **Configuration security** – Password protection is provided to prevent tampering, allowing users to lock out some, all, or no groups of setup parameters.
- **Direction of rotation** – programmable.
- **Input Signals** – 0/4 to 20 mA, 0/1 to 5 Vdc, 0 to 10 Vdc, Digital RS485 Modbus RTU protocol, or Series 90 control.
- **Output Signals** – 0/4 to 20 mA, 0/1 to 5 Vdc or slidewire emulation.
- **Accurate Positioning** – Motor/gear train provides accurate positioning with almost instantaneous start/stop characteristics.
- **Stall Alarm** – provides alarm output in the event of actuator stall due to overload.

Smart Options

HercuLink® Software – loaded onto the users Palm PDA, laptop PC or desktop computer. This software allows you to configure or calibrate the actuator. In addition, maintenance information may be read, stored and later loaded in CSV format to the user's computer for maintenance tracking.

Hart™ Communication – For HART user's optional HART communications provides access to calibration, configuration, and maintenance data. In addition, the HART communications option is structured to work with the HART Asset Management Features.

Local HMI Configuration – Optional keypad and high intensity display is available (Figure 1). The display may be rotated in 90° increments for actuator mounting orientations other than horizontal.

Non-contact position sensing (NCS) – Herculine® 2002 only. See description next page.

Slidewire Emulation (SEC) – Herculine® 2001 and 2002 only. See text next page.

Auxiliary Relay Outputs – Programmable relay outputs can be used in place of auxiliary switch outputs to provide additional functionality such as indication of alarm status, control of other equipment, or to indicate position.

Battery Powered 232/485 converter and cable – used to connect the Palm PDA to the Herculine® actuator for communication.

Non-Contact Position Sensing

Available in the Herculine® 2002 actuator. The technology is a variable inductance, non-contact position sensor mounted directly to the actuator output shaft providing precision position sensing from 0 to 150 degrees (Figure 3). This technology eliminates maintenance items such as wipers, bearings, as well as static friction, hysteresis and electrical noise over a wide range of demanding environmental conditions. Typically used in very demanding applications where downtime is not an option.

Slidewire Emulation

Available in the Herculine® 2001/2002 actuator. The Slidewire Emulation Circuit (SEC) emulates the proportional voltage output of a typical slidewire through a high impedance circuit. The voltage output is proportional to the supply voltage and shaft position. If ordered on the 2002 model, a non-contact position sensor is used to determine shaft position in place of the slidewire. Typically used in very demanding applications where downtime is not an option.

Potentiometer Sensing

An advanced high cycle film potentiometer for position sensing for true position feedback is available as an option on the Herculine® 2000 BMU model and standard on Herculine® 2001 EEU model.

Self-locking/releasing Gear Train

The worm gear output combination is self-locking and self-releasing and maintains position upon loss of power. It is designed to hold greater than two times the rated output torque in a back-driving condition. This design provides superior reliability without the maintenance associated with other self-locking and brake mechanisms.

General Features

- **Motor** - no burn out motor can be stalled up to 100 hours without damage to the actuator.
- **Duty Cycle** – Continuous duty cycle
- **Any position mounting** – the actuator may be mounted in any orientation without degrading performance.
- **Power Requirements** – Low power consumption 120/240 Vac, 50/60 Hz, single phase $\leq 0.6/0.3$ Amp.
- **Enclosure** – Rugged, Die cast aluminum NEMA 4X industrial grade enclosure.
- **Low Maintenance** – Simple-proven design means high reliability/low maintenance.
- **Limit Switches** – Two end-of-travel electric limit switches are supplied as standard equipment with all Herculine® 2000 series actuators.
- **Warranty** – Exceptional warranty
- **Certification** – CSA (pending), UL, CE

General Options

- **Auxiliary Switches** – up to four additional SPDT switches are available.
- **Manual Operation** – a manual hand wheel is optional and used to operate the actuator when power is not available.
- **Auto-Manual** – electric hand switch with auxiliary contacts indicating an "Out-of-Auto" position is available for local electric control.
- **Competitive Mounting Plates** – to adapt the Herculine® actuators to Invensys (Barber-Colman) or Siemens (Landis & Staefa) mountings.
- **Linkage assemblies** – Pushrod assemblies for valve or damper connection.

Optional Local Display and Keypad for HercuLine® 2001 and 2002

A local display and keypad is optional for configuration and set-up (Figure 2). A high intensity 10-character LED display and simple push buttons provide quick access for actuator set up and status information. If relay outputs are specified, all configuration can be done through either the local HMI interface or the HercuLink® configurator. HercuLink® Palm PDA software or HART™ communications is available for those ordering units without the display and keypad.

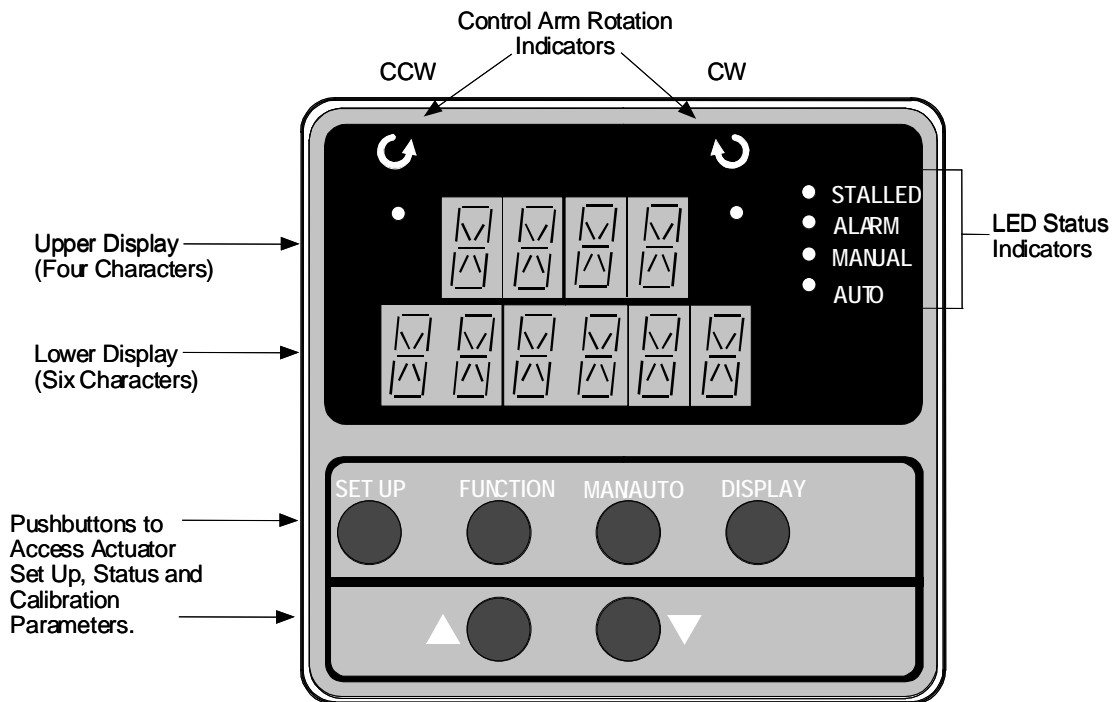
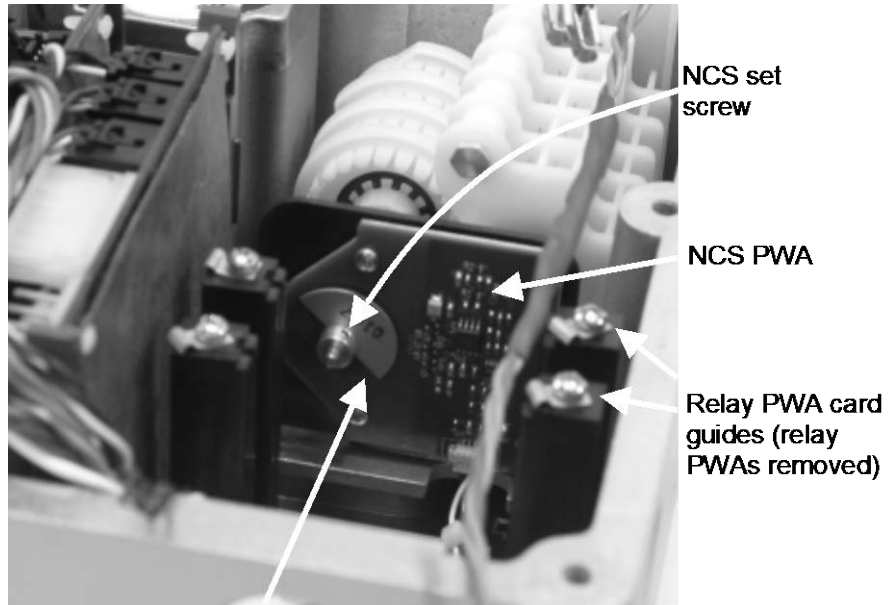

Figure 1 Local HMI (Display and Keypad)

Non-Contact Sensor



NCS Spoiler (shown at full
150 degree travel CCW)

Figure 2 Non-Contact Sensor Assembly (HercuLine® 2002)

HercuLink® Computer Interface

HercuLink® Computer software enables access to programming and communication functions available as standard with the HercuLine® 2001 and 2002 actuators without the added expense of the keypad & display HMI. Using a Palm™ PDA, laptop PC or desktop computer, HercuLink® software, and a RS232/485 converter users may configure, calibrate, and access maintenance information locally or remotely to the actuator.

Using HercuLink® software the computer may be used as a master device over a Modbus network to access information to/from the actuators and to control the device. Set-up configurations may also be stored on the computer for download to other HercuLine® devices. Information may be stored on the users PC in CSV format for use in preventative maintenance programs.

- Certified on Palm™ m125, m130, and m505.
- Compatible with Palm OS3.5 or higher.
- Compatible with Windows 2000 or XP operating systems
- Minimum system requirements:
 - Windows 2000 (w/service pack 2), Windows NT (w/service pack 5), Windows ME, Windows XP
 - 200 MHz Pentium with 64 Megs Ram

Palm™ is a trademark of Palm, Inc.

HotSync® is a registered trademark of Palm Computing, Inc.

HercuLink® is a trademark of Honeywell

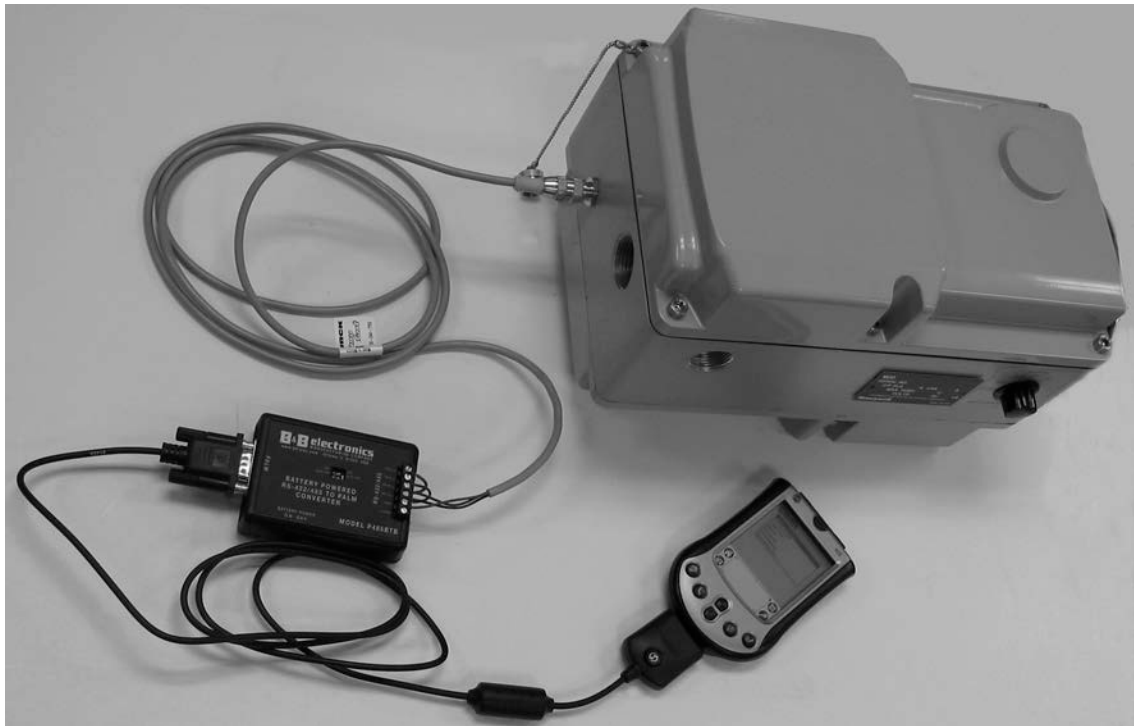

Figure 3 PDA connection

Set Up/Configuration Parameters for Keypad & Display or HercuLink® Software

Configuration parameters are logically grouped and accessed using the local HMI. Actuator calibration is also accomplished through a simple procedure using the keypad. By pressing the SETUP button on the HMI, you can step through the set up groups that contain all of the configuration parameters. The table below summarizes the configuration parameters available within the various set up groups. Full details of all configuration parameters are found in the *HercuLine® 2000 Series Actuator Installation, Operation and Maintenance Manual*, document number 62-86-25-10.

Set Up Group	Configuration Parameter Selections/Settings	
<p>SET INPUT— Selects various parameters that define actuator operation.</p>	<p>IN TYP – Input Actuation Type INP HI – Input High Range Value INP LO – Input Low Range Value FILTYP – Input Filter Type LPFILT – Low Pass Filter Time Constant Direct – Actuator Rotation Dband – Input Deadband</p>	<p>FSFTYPH – FailsafeHI Type FsFVALH – FailsafeHI Value FSFTYPL – FailsafeLO Type FsFVALL – FailsafeLO Value CHAR – Input Characterization Type CUST – Custom Characterization Type</p>
<p>SET RELAY— When the actuator is equipped with optional relays, this set up group allows you to set relay action for various actuator operating conditions. Contact closure can be wired to external annunciators or alarm points to indicate conditions for any of the Relay Types.</p>	<p>RTYPn – Relay Type Input Range Position Range Deviation Upper or Lower Limit Travel Temperature High or Low Cycle Count Motor Stalled Manual Mode Power Up Test Failure Input Signal Failure Position Sensor Signal Failure Digital Input Closure Total Degrees Traveled</p>	<p>RnnVAL – Relay Value Rnn HL – Relay High/Low RLYnHY – Relay Hysteresis</p>
<p>SET CUROUT— Selects the current (or voltage) output range of the actuator.</p>	<p>CUROUT - Output Signal Range 4 – 20 mA 0 – 20 mA 1 – 5 V 0 – 5 V Or SWE</p>	
<p>SET COMM— Actuator can be defined as a master or slave device on a Modbus RTU RS-485 loop. Operating setpoint can be transmitted to the actuator and operating status can be read when connected to supervisory control systems.</p>	<p>COMM – Communications Parameters ADDRES – Device Address BAUD – Baud Rate XmtDLY – Response Delay DBLBYT – Floating Point Data Format</p>	
<p>SET DIGINP— Selects digital input action upon contact closure.</p>	<p>DIGINP – Digital Input State Endpos – End Position Value</p>	
<p>SET DISPLA— Selects desired decimal places and engineering units for local display</p>	<p>DECMAL – Decimal Point Location EUNITS – Units Display UNITS – Display Units</p>	
<p>CAL INPUT, MTR, CURENT— If needed, field calibration of the actuator input, motor position and actuator output can be performed using the local keypad and display.</p>		

Set Up Group	Configuration Parameter Selections/Settings	
SET LOCK — Enables lock out or access to selected set up group parameters and calibration values.	LOCKID – Set Security Password LOCK – Lock Out MAENAB – Mode button lockout	
READ STATUS — Displays failsafe condition and the results of various diagnostics performed during power up.	FAILSF – Failsafe RAMTST – RAM Test Diagnostic SEETST – Serial EEPROM Test Diagnostic CFGTST – Configuration Test Diagnostic CALTST – Calibration Test Diagnostic	
SET DRVINP — Allows access to actuator device information.	VERNON – Firmware Version SPEED – Stroke Speed POWER – Power Input Voltage and Line Frequency TAG – Tag Name DMFG – Manufacturing Date LREP – Date of Last Repair LCAL – Date of Last Field Calibration REPTYP – Repair Type	
SET MAINT — Allows access to parameters that monitor operating conditions.	TEMP – Actuator Temperature TEMPHI – High Temperature Limit TEMPLO – Low Temperature Limit ACSTA – Accumulated Stall Time STARTS – Accumulated Motor Starts RLnCNTS – Relay Cycle Counts REGNn – Accumulated Motor Starts TOTDEG – Total degrees traveled MANRST – Reset Maintenance Statistics LD CAL – Restore Calibration LD CFG – Restore Configuration SYSRST – System Restart	

Specifications – General

Physical			
Weight	2000: 25 lb. (11.36 kg) 2001,2002: 27 lbs. (12.27 kg)		
Enclosure	Precision-machined die cast aluminum housing, finished in light gray powder coat epoxy.		
Gear Train	Alloy steel, high efficiency steel spur gear primary train. Precision ground, self-locking/self releasing worm gear final mesh.		
Mechanical Stops	Factory set at 90° or 150° (+/-5°).		
Storage Temperature	-40 °C to +93 °C (-40 °C to +200 °F)		
Relative Humidity	0 % to 99 % R.H. non-condensing over the full operating temperature range.		
Scale	0 % to 100 % corresponding to full crank arm travel.		
Crank Arm	Adjustable radii 1.0 in (25.4mm) to a maximum of 2.8 in (71.1mm). Position adjustable through 360° rotation.		
Output Shaft	0.625+/- .005 in (15.88 +/- .13mm) diameter (round)		
Rotation	90° or 150° degrees between 0 % and 100 % on scale, limited by mechanical stops.		
Manual Hand wheel (option)	Provides a means of positioning the actuator in the event of a power failure or set-up.		
Lubrication	Texaco Starplex 2 EP Grease		
Output Torque/Full Travel Stroking Time	Torque lb-in (N M)	50 Hz (90°/150°)	60 Hz (90°/150°)
	50 / (6.0)	4.5 / 7.5	4 / 6
	100 / (11.5)	9 / 15	7 / 12
	200 / (22.5)	18 / 30	15 / 25
	400 / (45.0)	36 / 60	30 / 50
	400 / (45.0)	54 / 90	45 / 75
Electrical			
Mains Supply	100-130 Vac single phase, 50 Hz or 60 Hz 200-240 Vac single phase, 50 Hz or 60 Hz		
Motor	Instant start/stop, non-coasting, non-burnout, continuous duty, permanent magnet, synchronous induction motor. Can be stalled up to 100 hours without damage.		
Motor Current	= No load = full load = locked rotor = 0.4 amp for 120Vac, 0.2 amp for 240 Vac		
Loss of Power	Stays in place on loss of power		
Local Auto/Manual Switch	Optional – Allows local and automatic operation of the actuator.		
End of travel Limit Switches	Standard – adjustable to limit actuator travel to less than 90 or 150 degrees respectively		
Auxiliary Switches/Relays	Optional – Up to 4 additional SPDT switches rated at (11 A at 277 Vac).		
Certifications			
Approvals	CSA/UL (Standard) CE Compliant (optional)		
Enclosure Rating	Type 4 (NEMA 4), IP66 (standard)		
Torque Settings of Crank Arm Bolts			
Clamp Bolt	88 lb-in (10 N-m)		

Electrical and Performance Specifications

HercuLine® 2000 Series

	HercuLine® 2002	HercuLine® 2001	Herculine® 2000
Input Signals	Analog: <ul style="list-style-type: none"> 0/4 to 20 mA (With CPU PWA jumper in current position) 0/1 to 5 Vdc 0 to 10 Vdc Digital: <ul style="list-style-type: none"> Modbus RTU (RS485) 	Analog: <ul style="list-style-type: none"> 0/4 to 20 mA (With CPU PWA jumper in current position) 0/1 to 5 Vdc 0 to 10 Vdc Series 90 control Digital: <ul style="list-style-type: none"> Modbus RTU (RS485) 	120 Vac drive open/120 Vac drive close 240 Vac drive open/240 Vac drive close
Isolation	Input signal, output signal and power are isolated from each other.		NA
Load Requirement (4-20)	Current Out — 0 to 10K Ohms		NA
Input Impedance	0/4 to 20 mA 0/1 to 5 Vdc 0-10 Vdc	250 ohms 10 K ohms	NA
Feedback	0 to 20 mA, 4 to 20 mA 0 to 5 Vdc & 1 to 5 Vdc with 250 ohm resistor, (0 to 16 Vdc with 800 ohm resistor)		Dual output 10K Ohms over 90 degrees (135 ohms with 158 resistor) Dual output 10K Ohms over 150 degrees (135 ohms with 158 resistor)
	Slidewire emulation - Provides output voltage ratiometric to shaft position and potentiometric to supply voltage (1 Vdc to 18 Vdc) without a slidewire. Emulates a 100 ohm to 10K Ohms slidewire. 10 mA output maximum.		
Communications	Modbus RTU or optional HART™		NA
Operating Temperature	-40°C to +75 °C (-40°F to +170 °F)		-40°C to +85 °C (-40°F to +185 °F)
Position sensing	Non-contact position sensor	10K Ohms film potentiometer	Optional dual 10K Ohms film potentiometers
Sensitivity	0.2 % to 5 % of 90° span, proportional to deadband		NA
Hysteresis	Less than 0.4 % of full scale		NA
Deadband	0.2 % to 5 % of 90° span, programmable. Shipped at 0.5 %		NA
Repeatability	0.2 % of 90° span		NA
Repositions (minimum @ 90 or 150 degree stroke)	Table 1 option -050- 160 Table 1 option -100- 290 Table 1 option -200- 450 Table 1 option -400- 700 Table 1 option -600- 900	120 250 400 400 400	500
Voltage/ Supply Stability	0.25 % of span with +10/-15 % voltage change		NA
Temperature Coefficient	Less than ± 0.030 % of span per degree C for 0 °C to 50 °C Less than ± 0.05 % of span per degree C for -40 °C to 75 °C		NA

	HercuLine® 2002	HercuLine® 2001	Herculine® 2000
Zero Suppression	90 % of span.		NA
Input Filters	Selectable spike and low pass filters.		NA
Solid State Motor Control	Two triac switches for clockwise or anti-clockwise motor operation. Transient voltage protection provided.		NA
Failsafe operation	If input signal exceeds configured input range. Selectable and adjustable.		NA
Direction of Rotation	Field programmable		Wire swap
Duty Cycle	Continuous		
Programmable Functions	Selectable and configurable operating parameters: <ul style="list-style-type: none"> • Input range • Input filtering • Input characterization • Security • Digital Input action • Deadband • Failsafe on loss of input signal • Failsafe on loss of position sensor • Direction of rotation • Relay closure action • Communication parameters • Split range operation • Output range • Alarms 		NA

Note: Model SA2003 is a replacement for M640A Actionator

<https://www.honeywellprocess.com/en-US/explore/products/instrumentation/Pages/Actuators.aspx>

Actuator Crank Arm

The Herculine® 2000 Series Actuators come standard with a 2.8 inch (71.12mm) crank arm (Figure 4). The crank arm uses linkage kits (above). Adjustable radius (1.0 in (25.4mm) to 2.80 in (71.12mm)). Position adjustable through 360° rotation.

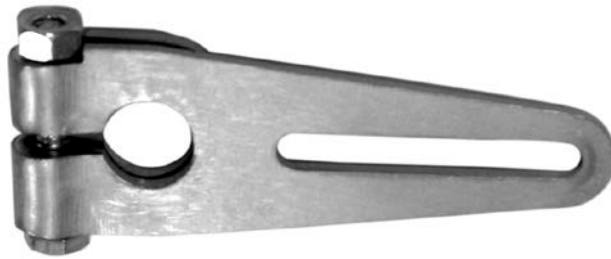
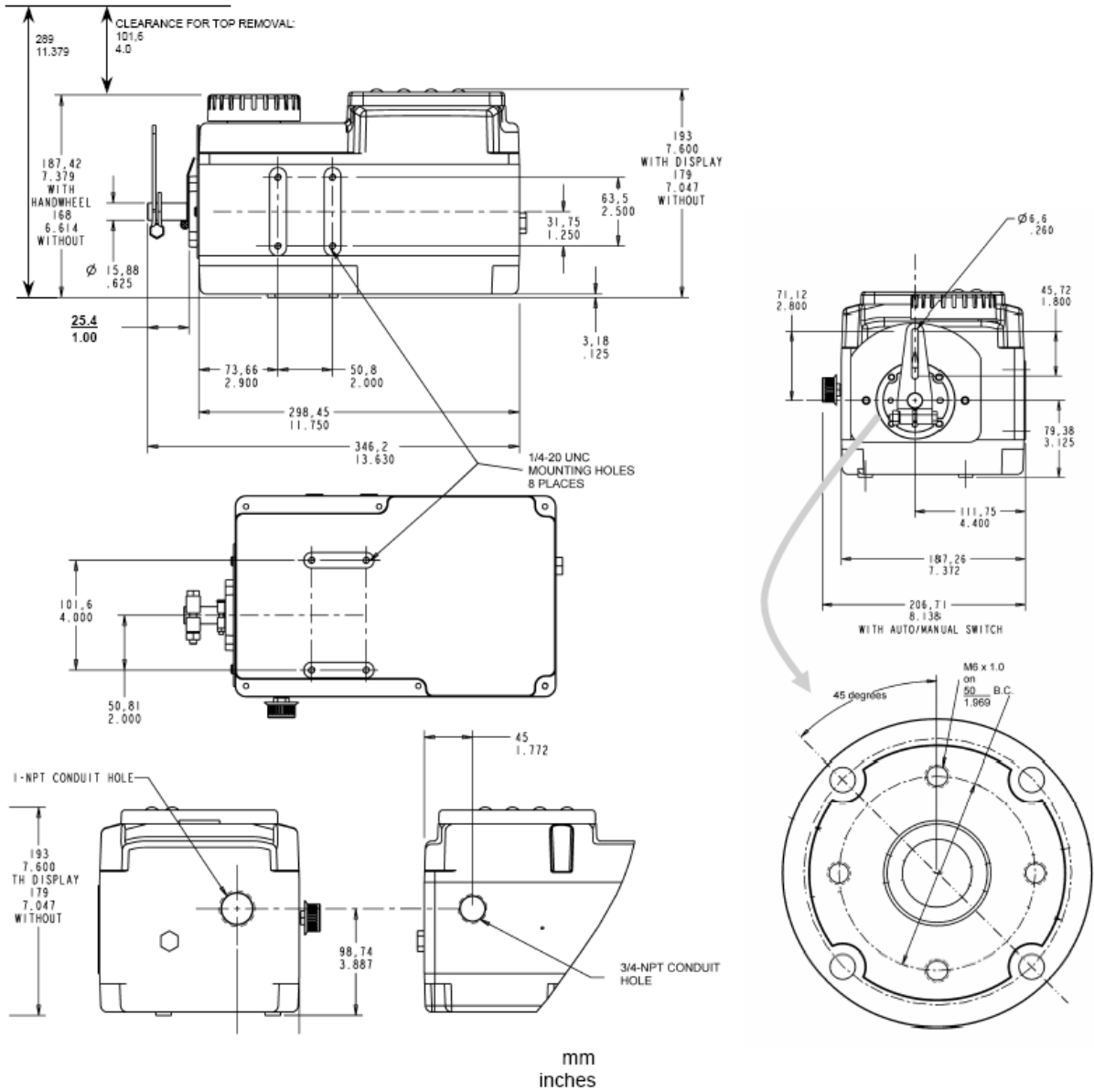

Figure 4 Standard 2.8" (71.12mm) Crank Arm



Figure 5 Crank Arm with optional ball joint and push rod

Outline Dimension Drawings



Model Selection Guide

Model Selection Guides are subject to change and are inserted into the specifications as guidance only. Prior to specifying or ordering a model check for the latest revision Model Selection Guides.

Honeywell

62-86-16-21
Issue 22
Page 1 of 2

2000 Series Model Selection Guide HercuLine[®] Actuators

Instructions

- Select the desired key number. The arrow to the right marks the selection available.
- Make the desired selections from Tables I thru VIII using the column below the arrow.
A dot (•) denotes unrestricted availability.

Key Number	I	II	III	IV	V	VI	VII	VIII	IX
_____	_____	_____	_____	_____	_____	_____	_____	_____	_____

KEY NUMBER - Motor Selection	Selection	Availability			
Basic Motor Unit (no electronics)	2000	↓			
Basic Motor Unit plus Digital Electronics	2001		↓		
Enhanced Performance Motor Unit with Non-contact Position Sensing	2002			↓	
Unidirectional Motor (M640D Replacement)	2003				↓

TABLE I - TORQUE & SPEED SELECTION (speed per 150 degree rotation)

Torque, lb-in/(N-M)	50Hz (90°/150°)	60Hz (90°/150°)				
50 / (6.0)	4.5 / 7.5 sec	4 / 6 sec	050	•	•	•
100 / (11.5)	9 / 15 sec	7 / 12 sec	100	•	•	•
200 / (22.5)	18 / 30 sec	15 / 25 sec	200	•	•	•
400 / (45.0)	36 / 60 sec	30 / 50 sec	400	•	•	•
400 / (45.0)	54 / 90 sec	45 / 75 sec	600	•	•	•

TABLE II - ROTATION

Travel					
90 degrees	090	•	•	•	•
150 degrees	150	•	•	•	•
360 degrees	360				•

TABLE III - POWER SUPPLY

Single Phase	100 - 130 Vac, 60 Hz	126	•	•	•
	100 - 130 Vac, 50 Hz	125	•	•	•
	200 - 240 Vac, 60 Hz	246	•	•	•
	200 - 240 Vac, 50 Hz	245	•	•	•

TABLE IV - ANALOG INPUT/OUTPUT SIGNALS

Input	3 Wire Drive up/down	0 __	•		
	0/4-20 mA, 0/1-5 Vdc, 0-10 Vdc	2 __		•	
	0/4-20 mA, 0/1-5 Vdc, 0-10 Vdc	3 __			•
	0 to 135 ohm input (Series 90 control)	4 __			a
	Contact Input for 2003	6 __			
Output	None	_ 00	•	•	•
	(Note 1) Dual 1000 Ohm (1000 ohms over 150 degrees)	_ 15	b		
	(Note 1) Dual 1000 Ohm (1000 ohms over 90 degrees)	_ 19	c		
	Slidewire Emulation	_ 60		•	
	Slidewire Emulation	_ 65			•
	0/4-20mAdc (0/1-5 Vdc, 0-16 Vdc)	_ 80		•	
0/4-20mAdc (0/1-5 Vdc, 0-16 Vdc)	_ 85			•	

TABLE V - SWITCH AND RELAY OUTPUTS (2 end-of-travel limit switches are standard)

Auxiliary Outputs	No Auxiliary Switches	0 _	•	•	•
	2 Auxiliary Switches	2 _	•	•	•
	4 Auxiliary Switches	4 _	•	•	•
Relay Outputs	No Relays	_ 0	•		•
	2 Programmable Relay Outputs	_ 2		•	
	2 Programmable Relay Outputs	_ 3			•
	4 Programmable Relay Outputs	_ 4		•	•

TABLE VI - OPTIONS		Selection	Availability			
			2000	2001	2002	2003
Local keypad/ display	No local display interface supplied (Note 2)	0_____	*	*	*	*
	Integrally mounted local display/keypad interface	1_____		*	*	
Local Auto/ manual switch	No auto/manual switch	_0_____	*	*		*
	Auto/manual switch with "Out of Auto Contact"	_1_____	*	*		
	Auto/manual switch with "Out of Auto Contact"	_2_____			*	
Handwheel	No Handwheel	__0____	*	*	*	*
	Handwheel	__1____	*	*	*	
Certificates	None	___0___	*	*	*	*
	Certificate of Conformance	___1___	*	*	*	*
Approvals	UL Type 4/IP66, CSA (Note 4)	___0___	*	*	*	*
	CE	___1___	*	*	*	*
Shipped Rotation	Counter clockwise shaft rotation on increasing signal	___0___	*	*	*	*
	Clockwise shaft rotation on increasing signal	___1___	*	*	*	*

TABLE VII - COMMUNICATIONS/PROTOCOL

None	No communications option board or protocol	0	*			*
Modbus RTU RS485	RS-485 Modbus compliant - standard with EEU	1		*	*	*
HART 5	HART Communications Protocol 5	2		*	*	
HART 6	HART Communications Protocol 6	3				

TABLE VIII - MANUALS

Standard	English	0	*	*	*	*
----------	---------	---	---	---	---	---

TABLE IX - FACTORY OPTIONS

Factory Options	None	00	*	*	*	*
	ECC	EC	*	*	*	*

Restrictions

Restriction Letter	Available Only With		Not Available With	
	Table	Selection	Table	Selection
a	IV	_00	IV	_60, _80
b	II	150	II	090
c	II	090	II	150

ACCESSORIES

Mounting Hardware	Mounting plate adapter for Barber Colman Series MP495	51452354-501	
	Mounting plate adapter for Landis & Staefa SQM53/56	51452354-502	
	Direct Couple Valve Hardware	51452354-503	
	North American Valve Retrofit Kit	51452354-511	
	Linkage Assembly	Ball joint for 5/16" dia. Pushrod	51452354-504
		Pushrod 12 in. (304,5 mm) long, 5/16 " dia.	51452354-505
		Pushrod 18 in. (457,2 mm) long, 5/16 " dia.	51452354-506
		Pushrod 24 in. 609,6 mm) long, 5/16 " dia.	51452354-507
Pushrod 48 in. (1219,2 mm) long, 5/16 " dia.	51452354-508		
HART	Turk Cable for Handheld Connection	51452352-501	
Handheld Config. (Note 3)	HercuLink™ PC and Palm PDA Software	51452354-509	
	Battery powered 232/485 converter with cable	51452354-510	
V51 Valve Kits	HercuLine 2000 V51 2.5" - 3" Valve Mounting Kit	51452354-513	
	HercuLine 2000 V51 4" Valve Mounting Kit	51452354-514	

- Notes:**
- 135 ohm available by parallelling 1K potentiometer with 158 Ohm resistor (supplied).
 - HercuLink™ software (pn 51452354-509), RS232/485 converter (pn 51452354-510), customer supplied Palm™ PDA running OS3.5 or higher and Palm serial cable are required for the 2001 and 2002 actuators if no display is selected.
 - Requires PDA manufacturer's serial interface cable.
 - CSA approval is good for 75°C and a maximum relay load of 3.5 amps or 70°C with a relay load of 5 amps.

Warranty/Remedy

Honeywell warrants goods of its manufacture as being free of defective materials and faulty workmanship. Contact your local sales office for warranty information. If warranted goods are returned to Honeywell during the period of coverage, Honeywell will repair or replace without charge those items it finds defective. The foregoing is Buyer's sole remedy and is **in lieu of all other warranties, expressed or implied, including those of merchantability and fitness for a particular purpose**. Specifications may change without notice. The information we supply is believed to be accurate and reliable as of this printing. However, we assume no responsibility for its use.

While we provide application assistance personally, through our literature and the Honeywell web site, it is up to the customer to determine the suitability of the product in the application.

Sales and Service

For application assistance, current specifications, ordering, pricing, and name of the nearest Authorized Distributor, contact one of the offices below.

ASIA PACIFIC

Honeywell Process Solutions,

Phone: + 800 12026455 or
+44 (0) 1202645583

(TAC) hfs-tac-support@honeywell.com

Australia

Honeywell Limited
Phone: +(61) 7-3846 1255
FAX: +(61) 7-3840 6481
Toll Free 1300-36-39-36
Toll Free Fax:
1300-36-04-70

China – PRC - Shanghai

Honeywell China Inc.
Phone: (86-21) 5257-4568
Fax: (86-21) 6237-2826

Singapore

Honeywell Pte Ltd.
Phone: +(65) 6580 3278
Fax: +(65) 6445-3033

South Korea

Honeywell Korea Co Ltd
Phone: +(822) 799 6114
Fax: +(822) 792 9015

EMEA

Honeywell Process Solutions,

Phone: + 800 12026455 or
+44 (0) 1202645583

Email: (Sales)

FP-Sales-Apps@Honeywell.com

or

(TAC)

hfs-tac-support@honeywell.com

Web

Knowledge Base search
engine <http://bit.ly/2N5Vldi>

AMERICAS

Honeywell Process Solutions,

Phone: (TAC) (800) 423-9883
or (215) 641-3610

(Sales) 1-800-343-0228

Email: (Sales)

FP-Sales-Apps@Honeywell.com

or

(TAC)

hfs-tac-support@honeywell.com

Web

Knowledge Base search
engine <http://bit.ly/2N5Vldi>

Specifications are subject to change without notice

For more information

To learn more about Actuators,
visit www.honeywellprocess.com
Or contact your Honeywell Account Manager

Process Solutions

Honeywell
1250 W Sam Houston Pkwy S
Houston, USA, TX 77042

Honeywell Control Systems Ltd
Honeywell House, Skimped Hill Lane
Bracknell, England, RG12 1EB

Shanghai City Centre, 100 Jungi Road
Shanghai, China 20061

www.honeywellprocess.com

61-86-03-14
October 2019
©2019 Honeywell International Inc.

Honeywell